

ETSI EN 304 220-1 V1.2.1 (2024-08)



**Wideband data transmission SRD;
Harmonised Standard for access to radio spectrum;
Part 1: Wideband data transmission devices: network access
points operating in the frequency bands 863 MHz to 868 MHz
and 915,8 MHz to 919,4 MHz**

Reference

DEN/ERM-TG28-556

Keywords

harmonised standard, SRD

ETSI

650 Route des Lucioles
F-06921 Sophia Antipolis Cedex - FRANCE

Tel.: +33 4 92 94 42 00 Fax: +33 4 93 65 47 16

Siret N° 348 623 562 00017 - APE 7112B
Association à but non lucratif enregistrée à la
Sous-Préfecture de Grasse (06) N° w061004871

Important notice

The present document can be downloaded from the
ETSI [Search & Browse Standards](#) application.

The present document may be made available in electronic versions and/or in print. The content of any electronic and/or print versions of the present document shall not be modified without the prior written authorization of ETSI. In case of any existing or perceived difference in contents between such versions and/or in print, the prevailing version of an ETSI deliverable is the one made publicly available in PDF format on [ETSI deliver](#).

Users should be aware that the present document may be revised or have its status changed,
this information is available in the [Milestones listing](#).

If you find errors in the present document, please send your comments to
the relevant service listed under [Committee Support Staff](#).

If you find a security vulnerability in the present document, please report it through our
[Coordinated Vulnerability Disclosure \(CVD\)](#) program.

Notice of disclaimer & limitation of liability

The information provided in the present deliverable is directed solely to professionals who have the appropriate degree of experience to understand and interpret its content in accordance with generally accepted engineering or other professional standard and applicable regulations.

No recommendation as to products and services or vendors is made or should be implied.
In no event shall ETSI be held liable for loss of profits or any other incidental or consequential damages.

Any software contained in this deliverable is provided "AS IS" with no warranties, express or implied, including but not limited to, the warranties of merchantability, fitness for a particular purpose and non-infringement of intellectual property rights and ETSI shall not be held liable in any event for any damages whatsoever (including, without limitation, damages for loss of profits, business interruption, loss of information, or any other pecuniary loss) arising out of or related to the use of or inability to use the software.

Copyright Notification

No part may be reproduced or utilized in any form or by any means, electronic or mechanical, including photocopying and microfilm except as authorized by written permission of ETSI.

The content of the PDF version shall not be modified without the written authorization of ETSI.

The copyright and the foregoing restriction extend to reproduction in all media.

© ETSI 2024.
All rights reserved.

Contents

Intellectual Property Rights	8
Foreword.....	8
Modal verbs terminology.....	9
1 Scope	10
2 References	10
2.1 Normative references	10
2.2 Informative references.....	11
3 Definition of terms, symbols and abbreviations.....	12
3.1 Terms.....	12
3.2 Symbols.....	14
3.3 Abbreviations	14
4 Technical requirements specifications	15
4.1 Environmental profile.....	15
4.2 General performance criteria	15
4.3 Requirements for transmitters	15
4.3.1 Frequency error.....	15
4.3.1.1 Applicability.....	15
4.3.1.2 Description	16
4.3.1.3 Limits	16
4.3.1.4 Conformance.....	16
4.3.2 Effective radiated power	16
4.3.2.1 Applicability.....	16
4.3.2.2 Description	16
4.3.2.3 Limits	16
4.3.2.4 Conformance	16
4.3.3 Occupied bandwidth	16
4.3.3.1 Applicability.....	16
4.3.3.2 Description	16
4.3.3.3 Limits	16
4.3.3.4 Conformance.....	17
4.3.4 Transmitter spectrum emission mask.....	17
4.3.4.1 Applicability.....	17
4.3.4.2 Description	17
4.3.4.3 Limits	17
4.3.4.4 Conformance.....	17
4.3.5 Transmitter unwanted emissions in the spurious domain	18
4.3.5.1 Applicability.....	18
4.3.5.2 Description	18
4.3.5.3 Limits	18
4.3.5.4 Conformance.....	18
4.3.6 Duty cycle.....	18
4.3.6.1 Applicability.....	18
4.3.6.2 Description	18
4.3.6.3 Limits	19
4.3.6.4 Conformance.....	19
4.3.7 Transient power	19
4.3.7.1 Applicability.....	19
4.3.7.2 Description	19
4.3.7.3 Limits	19
4.3.7.4 Conformance.....	19
4.4 Requirements for receivers.....	19
4.4.1 Receiver sensitivity.....	19
4.4.1.1 Applicability.....	19
4.4.1.2 Description	19

4.4.1.3	Limits	20
4.4.1.4	Conformance	20
4.4.2	Adjacent channel selectivity	20
4.4.2.1	Applicability	20
4.4.2.2	Description	20
4.4.2.3	Limits	20
4.4.2.4	Conformance	20
4.4.3	Receiver spurious response rejection	20
4.4.3.1	Applicability	20
4.4.3.2	Description	21
4.4.3.3	Limits	21
4.4.3.4	Conformance	21
4.4.4	Blocking	21
4.4.4.1	Applicability	21
4.4.4.2	Description	21
4.4.4.3	Limits	21
4.4.4.4	Conformance	21
4.4.5	Receiver spurious emission	21
4.4.5.1	Applicability	21
4.4.5.2	Description	21
4.4.5.3	Limits	22
4.4.5.4	Conformance	22
4.4.6	Receiver maximum input signal level	22
4.4.6.1	Applicability	22
4.4.6.2	Description	22
4.4.6.3	Limits	22
4.4.6.4	Conformance	22
4.5	Requirements for spectrum access	22
4.5.1	Clear channel assessment threshold	22
4.5.1.1	Applicability	22
4.5.1.2	Description	22
4.5.1.3	Limits	23
4.5.1.4	Conformance	23
4.5.2	Listen Before Talk (LBT)	23
4.5.2.1	Applicability	23
4.5.2.2	Description	23
4.5.2.3	Limits	23
4.5.2.4	Conformance	24
4.6	Functional Requirements	24
4.6.1	Master Network Access Point	24
4.6.1.1	Applicability	24
4.6.1.2	Description	24
4.6.1.3	Limits	24
4.6.1.4	Conformance	24
4.6.2	Network Access Point	24
4.6.2.1	Applicability	24
4.6.2.2	Description	25
4.6.2.3	Limits	25
4.6.2.4	Conformance	25
5	Testing for compliance with technical requirements	25
5.1	Environmental conditions for testing	25
5.2	General conditions for testing	25
5.2.1	General considerations	25
5.2.2	Presentation of equipment for testing purposes	25
5.2.2.1	General Considerations	25
5.2.2.2	Choice of model for testing	25
5.2.2.2.1	General considerations	25
5.2.2.2.2	EUT with an external RF connector	26
5.2.2.2.3	EUT without an external RF connector	26
5.2.2.3	Testing of modular equipment	26
5.2.3	Test power source	26

5.2.3.1	General	26
5.2.3.2	External test power source	27
5.2.3.3	Internal test power source	27
5.2.4	Thermal test conditions	27
5.2.5	Conducted measurements	27
5.2.5.1	Artificial antenna	27
5.2.6	Radiated measurements	27
5.2.7	Applicable measurement methods	27
5.2.8	Test signals for data	28
5.2.9	Measuring receiver	29
5.2.9.1	Description	29
5.2.9.2	Reference bandwidth	29
5.3	Conformance methods of measurement for transmitters	30
5.3.1	Frequency error	30
5.3.1.1	Test conditions	30
5.3.1.2	Radiated measurement	31
5.3.1.3	Conducted measurement	31
5.3.1.4	Measurement procedure for D-M1 test signal	31
5.3.1.5	Measurement procedure for other test signal	31
5.3.2	Effective radiated power	32
5.3.2.1	Effective Radiated Power (conducted measurement)	32
5.3.2.1.0	General	32
5.3.2.1.1	Test conditions	32
5.3.2.1.2	Measurement procedure	32
5.3.2.2	Effective radiated power (radiated measurement)	33
5.3.2.2.0	General	33
5.3.2.2.1	Test conditions	33
5.3.2.2.2	Measurement procedure	33
5.3.3	Occupied bandwidth	33
5.3.3.1	Test conditions	33
5.3.3.2	Radiated measurement	34
5.3.3.3	Conducted measurement	34
5.3.3.4	Measurement procedure	34
5.3.4	Transmitter spectrum emission mask	35
5.3.4.1	Test conditions	35
5.3.4.2	Radiated measurement	35
5.3.4.3	Conducted measurement	35
5.3.4.4	Measurement procedure	35
5.3.5	Transmitter unwanted emission in the spurious domain	35
5.3.5.1	Test conditions	35
5.3.5.2	Radiated measurement	36
5.3.5.3	Conducted measurement	36
5.3.5.4	Measurement procedure	36
5.3.5.4.1	Pre-scan	36
5.3.5.4.2	Measurement of the emissions identified during the pre-scan	37
5.3.6	Duty cycle	38
5.3.6.1	Test conditions	38
5.3.6.2	Radiated measurement	38
5.3.6.3	Conducted measurement	38
5.3.6.4	Measurement procedure	39
5.3.7	Transient power	39
5.3.7.1	Test conditions	39
5.3.7.2	Radiated measurement	39
5.3.7.3	Conducted measurement	39
5.3.7.4	Measurement procedure	40
5.4	Conformance test suites for receivers	41
5.4.1	Receiver sensitivity	41
5.4.1.1	Test Conditions	41
5.4.1.2	Radiated measurement	41
5.4.1.3	Conducted measurement	41
5.4.1.4	Measurement procedure	41
5.4.2	Adjacent channel selectivity	42

5.4.2.1	Test conditions	42
5.4.2.2	Radiated measurement	42
5.4.2.3	Conducted measurement	42
5.4.2.4	Measurement procedure	42
5.4.3	Receiver spurious response rejection	43
5.4.3.1	Test conditions	43
5.4.3.2	Radiated measurement	43
5.4.3.3	Conducted measurement	43
5.4.3.4	Measurement procedure	44
5.4.4	Blocking	44
5.4.4.1	Test conditions	44
5.4.4.2	Radiated measurement	45
5.4.4.3	Conducted measurement	45
5.4.4.4	Measurement procedure	45
5.4.5	Receiver spurious emission	46
5.4.5.1	Test conditions	46
5.4.5.2	Radiated measurement	46
5.4.5.3	Conducted measurement	46
5.4.5.4	Measurement procedure	46
5.4.5.4.1	Conducted measurement	46
5.4.5.4.2	Radiated measurement	47
5.4.6	Receiver maximum input signal level	47
5.4.6.1	Test conditions	47
5.4.6.2	Radiated measurement	47
5.4.6.3	Conducted measurement	48
5.4.6.4	Measurement procedure	48
5.5	Conformance test suites for spectrum access	49
5.5.1	Clear channel assessment threshold	49
5.5.1.1	Test conditions	49
5.5.1.2	Radiated measurement	49
5.5.1.3	Conducted measurement	49
5.5.1.4	Measurement procedure	50
5.5.2	Listen before talk	51
5.5.2.1	Test conditions	51
5.5.2.2	Radiated measurement	51
5.5.2.3	Conducted measurement	51
5.5.2.4	Measurement procedure	51
5.6	Conformance test suites for functional requirements	53
5.6.1	Master Network Access Point	53
5.6.1.1	Test conditions	53
5.6.1.2	Radiated measurement	53
5.6.1.3	Conducted measurement	53
5.6.1.4	Measurement procedure	54
5.6.2	Network Access Point (NAP)	54
5.6.2.1	Test conditions	54
5.6.2.2	Measurement Procedure	55

Annex A (informative):	Relationship between the present document and the essential requirements of Directive 2014/53/EU	57
-------------------------------	---	-----------

Annex B (normative):	Test sites and arrangements for radiated measurement	59
-----------------------------	---	-----------

B.1	General considerations	59
B.2	Radiation test sites	59
B.2.1	Open Area Test Site (OATS)	59
B.2.2	Semi Anechoic Room	60
B.2.3	Fully Anechoic Room (FAR)	61
B.2.4	Measurement Distance	62
B.3	Antenna	63
B.3.1	General considerations	63
B.3.2	Measurement antenna	63

B.3.3	Substitution antenna	63
B.4	Guidance on the use of radiation test sites	64
B.4.1	General considerations	64
B.4.2	Power supplies for the battery powered EUT	64
B.4.3	Site preparation	64
B.5	Coupling of signals.....	64
B.5.1	General	64
B.5.2	Data signals	65
B.6	Measurement procedures for radiated measurement	65
B.6.1	General considerations	65
B.6.2	Radiated measurements in an OATS or SAR.....	65
B.6.3	Radiated measurements in a FAR	66
B.6.4	Substitution measurement	66
B.6.5	Radiated measurement methods for receivers	66
B.7	Guidance for testing radiated technical requirements	66
B.7.0	General	66
B.7.1	Radio test suites and corresponding test sites.....	67
Annex C (informative): Selection of receiver parameters.....		68
C.0	Introduction	68
C.1	Receiver sensitivity	68
C.2	Receiver co-channel rejection	68
C.3	Receiver adjacent signal selectivity	68
C.4	Receiver spurious response rejection	68
C.5	Receiver blocking.....	68
C.6	Receiver radio-frequency intermodulation.....	69
C.7	Receiver dynamic range	69
C.8	Desensitization	69
C.9	Receiver unwanted emissions in the spurious domain	69
Annex D (normative): T_{On} time measurements		70
D.1	Measurement procedure	70
D.2	T _{Disregard} procedure	70
Annex E (normative): Test fixture		72
E.1	General considerations	72
E.2	Validation of the test-fixture in the temperature chamber.....	73
E.3	Mode of use.....	74
Annex F (informative): Properties of EUT		75
Annex G (informative): Maximum Measurement uncertainty		76
Annex H (informative): Bibliography.....		77
History		78

Intellectual Property Rights

Essential patents

IPRs essential or potentially essential to normative deliverables may have been declared to ETSI. The declarations pertaining to these essential IPRs, if any, are publicly available for **ETSI members and non-members**, and can be found in ETSI SR 000 314: "*Intellectual Property Rights (IPRs); Essential, or potentially Essential, IPRs notified to ETSI in respect of ETSI standards*", which is available from the ETSI Secretariat. Latest updates are available on the ETSI Web server (<https://ipr.etsi.org/>).

Pursuant to the ETSI Directives including the ETSI IPR Policy, no investigation regarding the essentiality of IPRs, including IPR searches, has been carried out by ETSI. No guarantee can be given as to the existence of other IPRs not referenced in ETSI SR 000 314 (or the updates on the ETSI Web server) which are, or may be, or may become, essential to the present document.

Trademarks

The present document may include trademarks and/or tradenames which are asserted and/or registered by their owners. ETSI claims no ownership of these except for any which are indicated as being the property of ETSI, and conveys no right to use or reproduce any trademark and/or tradename. Mention of those trademarks in the present document does not constitute an endorsement by ETSI of products, services or organizations associated with those trademarks.

DECT™, **PLUGTESTS™**, **UMTS™** and the ETSI logo are trademarks of ETSI registered for the benefit of its Members. **3GPP™** and **LTE™** are trademarks of ETSI registered for the benefit of its Members and of the 3GPP Organizational Partners. **oneM2M™** logo is a trademark of ETSI registered for the benefit of its Members and of the oneM2M Partners. **GSM®** and the GSM logo are trademarks registered and owned by the GSM Association.

Foreword

This Harmonised European Standard (EN) has been produced by ETSI Technical Committee Electromagnetic compatibility and Radio spectrum Matters (ERM).

The present document has been prepared under the Commission's standardisation request C(2015) 5376 final [i.3] to provide one voluntary means of conforming to the essential requirements of Directive 2014/53/EU on the harmonisation of the laws of the Member States relating to the making available on the market of radio equipment and repealing Directive 1999/5/EC [i.1].

Once the present document is cited in the Official Journal of the European Union under that Directive, compliance with the normative clauses of the present document given in Table A-1 confers, within the limits of the scope of the present document, a presumption of conformity with the corresponding essential requirements of that Directive, and associated EFTA regulations.

The present document is part 1 of a multi-part deliverable covering Wideband data transmission SRD; Harmonised Standard for access to radio spectrum, as identified below:

- Part 1: "Wideband data transmission devices: network access points operating in the frequency bands 863 MHz to 868 MHz and 915,8 MHz to 919,4 MHz";**
- Part 2: "Wideband data transmission devices: terminal node operating in designated bands 863 MHz to 868 MHz and 915,8 MHz to 919,4 MHz".

National transposition dates	
Date of adoption of this EN:	2 August 2024
Date of latest announcement of this EN (doa):	30 November 2024
Date of latest publication of new National Standard or endorsement of this EN (dop/e):	31 May 2025
Date of withdrawal of any conflicting National Standard (dow):	31 May 2026

Modal verbs terminology

In the present document "**shall**", "**shall not**", "**should**", "**should not**", "**may**", "**need not**", "**will**", "**will not**", "**can**" and "**cannot**" are to be interpreted as described in clause 3.2 of the [ETSI Drafting Rules](#) (Verbal forms for the expression of provisions).

"**must**" and "**must not**" are **NOT** allowed in ETSI deliverables except when used in direct citation.

1 Scope

The present document specifies technical characteristics and test methods to be used in the conformance assessment of wideband data transmission Short Range Device (SRD) network access point equipment in the frequency range 863 MHz to 868 MHz and 915,8 MHz to 919,4 MHz. The wideband data transmission device category covers radio devices that use wideband modulation techniques to access the spectrum. The present document specifies technical characteristics and methods of measurements for equipment operated in the following designated frequency bands given in Table 1-1.

Table 1-1: Designated frequency bands

SRD frequency bands	
863 MHz to 868 MHz	According to band no 84 of Commission Implementing Decision (EU) 2022/180 [i.7] and Annex 3 band a1 of CEPT/ERC/REC 70 03 [i.2].
915,8 MHz to 919,4 MHz	According to band a2 of Annex 3 of CEPT/ERC/REC 70 03 [i.2].
917,4 MHz to 919,4 MHz	According to band no 2 of Commission Implementing Decision (EU) 2022/172 [i.8].

In the designated bands the following types of equipment are defined:

- Type 1: Wideband Data Transmission Network Access Point (NAP) in data networks in 863,0 MHz to 868,0 MHz.
- Type 2: Wideband Data Transmission Master Network Access Point (NAP) in data networks in 915,8 MHz to 919,4 MHz and in 917,4 MHz to 919,4 MHz.
- Type 3: Wideband Data Transmission Network Access Point (NAP) in data networks in 915,8 MHz to 919,4 MHz and in 917,4 MHz to 919,4 MHz.

NOTE 1: The availability of the frequency bands for type 2 and type 3 equipment in the European Union and CEPT countries can be obtained from EFIS (<https://efis.cept.org/>) and is also listed in Appendices 1 and 3 of CEPT/REC 70-03 [i.2].

In addition, it should be noted that, in some countries, part or all of the bands for type 2 and type 3 equipment may be unavailable, and/or other frequency bands may be available, for networked and/or network based short range devices. See National Radio Interfaces (NRI) as relevant for additional guidance.

NOTE 2: The relationship between the present document and essential requirements of article 3.2 of Directive 2014/53/EU [i.1] is given Annex A.

2 References

2.1 Normative references

References are either specific (identified by date of publication and/or edition number or version number) or non-specific. For specific references, only the cited version applies. For non-specific references, the latest version of the referenced document (including any amendments) applies.

Referenced documents which are not found to be publicly available in the expected location might be found at <https://docbox.etsi.org/Reference/>.

NOTE: While any hyperlinks included in this clause were valid at the time of publication, ETSI cannot guarantee their long term validity.

Not applicable.

2.2 Informative references

References are either specific (identified by date of publication and/or edition number or version number) or non-specific. For specific references, only the cited version applies. For non-specific references, the latest version of the referenced document (including any amendments) applies.

NOTE: While any hyperlinks included in this clause were valid at the time of publication, ETSI cannot guarantee their long term validity.

The following referenced documents are not necessary for the application of the present document but they assist the user with regard to a particular subject area.

- [i.1] [Directive 2014/53/EU](#) of the European Parliament and of the Council of 16 April 2014 on the harmonisation of the laws of the Member States relating to the making available on the market of radio equipment and repealing Directive 1999/5/EC.
- [i.2] [CEPT/ERC/REC 70-03 \(12 February 2022\)](#): "Relating to the use of Short Range Devices (SRD)".
- [i.3] [Commission Implementing Decision C\(2015\) 5376 final of 4.8.2015](#) on a standardisation request to the European Committee for Electrotechnical Standardisation and to the European Telecommunications Standards Institute as regards radio equipment in support of Directive 2014/53/EU of the European Parliament and of the Council.
- [i.4] [ECC Report 261 \(01-2017\)](#): "Short Range Devices in the frequency range 862-870 MHz".
- [i.5] [ECC Report 246 \(01-2017\)](#): "Wideband and Higher DC Short Range Devices in 870-875.8 MHz and 915.2-920.8 MHz (companion to ECC Report 200)".
- [i.6] Recommendation ITU-T O.153 (10/92): "Basic parameters for the measurement of error performance at bit rates below the primary rate".
- [i.7] [Commission Implementing Decision \(EU\) 2022/180 of 8 February 2022](#) amending Decision 2006/771/EC as regards the update of harmonised technical conditions in the area of radio spectrum use for short-range devices.
- [i.8] [Commission Implementing Decision \(EU\) 2022/172 of 7 February 2022](#) amending Implementing Decision (EU) 2018/1538 on the harmonisation of radio spectrum for use by short-range devices within the 874-876 and 915-921 MHz frequency bands.
- [i.9] [ERC Recommendation 74-01 \(October 2021\)](#): "Unwanted Emission in the spurious domain".
- [i.10] EN 55016-1-1 (2019) part 1-1: "Specification for radio disturbance and immunity measuring apparatus and methods; Part 1: Radio disturbance and immunity measuring apparatus - Measuring apparatus", produced by CENELEC.
- [i.11] ETSI TR 100 028 (all parts) (V1.4.1): "Electromagnetic compatibility and Radio spectrum Matters (ERM); Uncertainties in the measurement of mobile radio equipment characteristics".
- [i.12] ETSI EG 203 336: "Guide for the selection of technical parameters for the production of Harmonised Standards covering article 3.1(b) and article 3.2 of Directive 2014/53/EU".
- [i.13] ETSI TR 102 273-4: "Electromagnetic compatibility and Radio spectrum Matters (ERM); Improvement on Radiated Methods of Measurement (using test site) and evaluation of the corresponding measurement uncertainties; Part 4: Open area test site".
- [i.14] ETSI TR 102 273-3: "Electromagnetic compatibility and Radio spectrum Matters (ERM); Improvement on Radiated Methods of Measurement (using test site) and evaluation of the corresponding measurement uncertainties; Part 3: Anechoic chamber with a ground plane".
- [i.15] ETSI TR 102 273-2: "Electromagnetic compatibility and Radio spectrum Matters (ERM); Improvement on Radiated Methods of Measurement (using test site) and evaluation of the corresponding measurement uncertainties; Part 2: Anechoic chamber".

3 Definition of terms, symbols and abbreviations

3.1 Terms

For the purposes of the present document, the following terms apply:

adjacent channel: frequency range equal to the width of the operating channel immediately above and immediately below the operating channel

NOTE: See Figure 3.1-1.

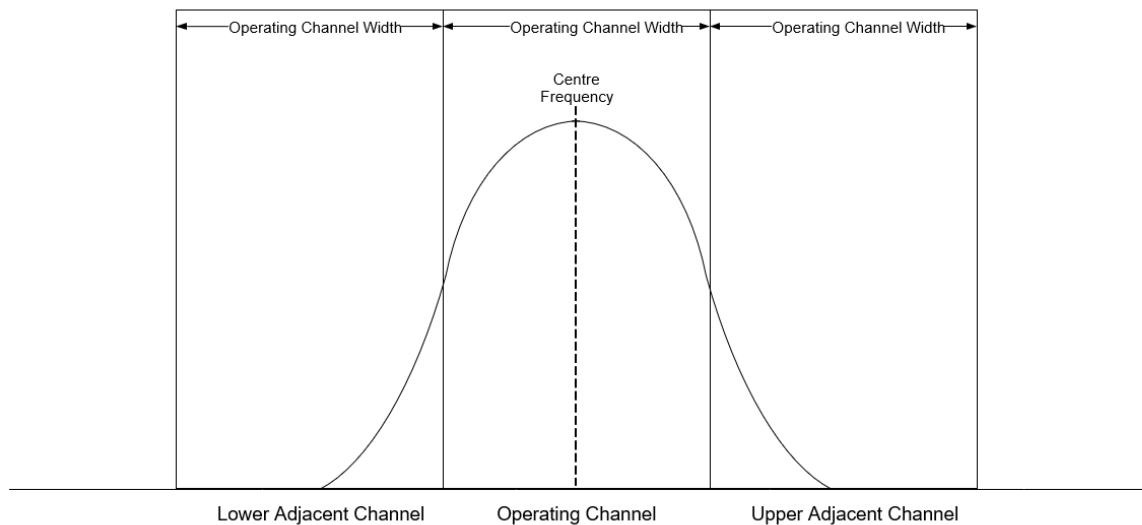

Figure 3.1-1: Adjacent channel definitions

Clear Channel Assessment (CCA): procedure of sensing the operating channel to determine whether or not it is occupied by a transmission

conducted measurements: measurements which are made using a direct 50 Ω connection to the equipment under test

centre frequency: centre frequency of the transmitted signal

continuous transmission: modulated transmission without interruption for the period of the test

data network: group of wirelessly communicating SRDs composed of a network access point and one or more terminal nodes

dedicated antenna: removable antenna supplied and tested with the radio equipment, designed as an indispensable part of the equipment

dialog: repeated transmit-response cycle between two devices within a transmission

disregard time ($T_{\text{Disregard}}$): interval below which two separate radio emissions in a channel are considered a single continuous transmitted burst

duty cycle: ratio, expressed as a percentage, of the cumulative duration of transmissions in an observation bandwidth within an observation interval divided by the observation interval

fixed SRD: SRD able to operate only at a fixed geographical location

integral antenna: permanent fixed antenna, which may be built-in, designed as an indispensable part of the equipment

Listen Before Transmit (LBT): mechanism by which an equipment applies Clear Channel Assessment (CCA) before transmission (also known as Listen Before Talk)

master NAP: NAP which enables the operation of nomadic and/or mobile devices

NOTE: Nomadic and mobile terminal nodes are under the control of master NAP in the frequency range of 915,8 MHz - 919,4 MHz and of 917,4 MHz - 919,4 MHz in Europe according to CEPT/ERC/REC 70-03 [i.2] and Commission Implementing Decision (EU) 2022/172 [i.8].

maximum transmission duration ($T_{\text{On-Max}}$): longest permitted transmission

minimum inter-transmission interval ($T_{\text{Off-Min}}$): minimum interval in a channel between two transmissions by the same device

mobile equipment: equipment in operation while moving

Network Access Point (NAP): fixed terrestrial SRD connecting one or more terminal nodes to an external network or service

network control information: data intended to construct or maintain a data network

network data: application data carried over a data network

nomadic equipment: equipment for which the location may change but is stationary while in use

nominal operating frequency: frequency at mid-point of the Operating Channel

observation bandwidth: bandwidth in which the energy of an equipment is considered for the purposes of assessing transmission timings

observation period: reference interval of time

occupied bandwidth: width of a frequency band such that, below the lower and above the upper frequency limits, the mean powers emitted are each equal to 0,5 % of the total mean power of a given emission

NOTE: See Figure 3.1-2.

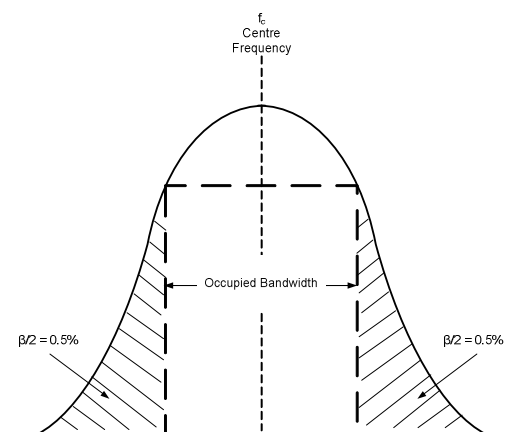

Figure 3.1-2: Signal Occupied Bandwidth

operating channel: frequency range in which transmissions occur

operating channel width: difference between frequency values of the high and low operating channel edges

Permitted Frequency Band (PFB): frequency band or sub-band within which the device is authorized to operate and to perform the intended function of the equipment

radiated measurements: measurements which involve the absolute measurement of a radiated electromagnetic field

signal threshold ($P_{\text{Threshold}}$): absolute signal level (in dBm) above which a transmission is considered to exist for a given receiver bandwidth

Terminal Node (TN): SRD generating and/or consuming network data

transmission: continuous radio emission, or sequence of emissions each separated by an interval $< T_{\text{Disregard}}$, with a signal level greater than the signal threshold in an operating channel

NOTE: See Figure 3.1-3.

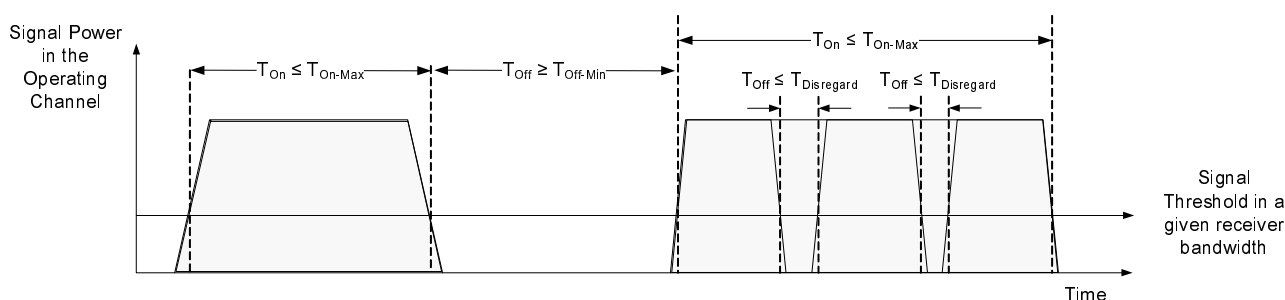

Figure 3.1-3: Transmission definitions

3.2 Symbols

For the purposes of the present document, the following symbols apply:

dB	decibel
dBc	dB relative to the carrier
dBm	power level unit expressed in decibel with reference to one milliwatt
kbps	kilobits per second
Mbps	Megabits per second
p	probability of bit error
ppm	frequency error relative to desired frequency expressed in parts per million
R	data rate
S	sensitivity of receiver
T_F	fixed listening time in CCA
T_L	total listening time in CCA
T_{PS}	pseudo random listening time in CCA
T_{MRI}	maximum response interval in CCA
T_{MRD}	maximum response duration in CCA
λ	wavelength

3.3 Abbreviations

For the purposes of the present document, the following abbreviations apply:

ACS	Adjacent Channel Selectivity
ARQ	Automatic Repeat reQuest
BER	Bit Error Ratio
CCA	Clear Channel Assessment
CEPT	European Conference of Postal and Telecommunications Administrations
CF	Centre Frequency
e.r.p.	effective radiated power
EC	European Commission
ECC	Electronic Communications Committee
EFIS	European Communications Office Frequency Information System
EU	European Union
EUT	Equipment Under Test
FAR	Fully Anechoic Room
FEC	Forward Error Correction
FOBWhigh	upper Frequency edge of Occupied Bandwidth
FOBWlow	lower Frequency edge of Occupied Bandwidth
ITU-R	International Telecommunication Union - Radiocommunication
LBT	Listen Before Talk

LPDA	Logarithmic Periodic Dipole Antenna
MAX	Maximum
MSR	Message Success Ratio
NAP	Network Access Point
NRI	National Radio Interfaces
OATS	Open Area Test Site
OBW	Occupied BandWidth
OCW	Operating Channel Width
RBW	Resolution BandWidth
RBW _{REF}	Reference BandWidth
RF	Radio Frequency
RMS	Root Mean Square
Rx	Receiver
SAR	Semi-Anechoic Room
SM	Spectrum management
SRD	Short Range Device
TN	Terminal Node
TR	Technical Report
Tx	Transmitter
VBW	Video Bandwidth
VSWR	Voltage Standing Wave Ratio

4 Technical requirements specifications

4.1 Environmental profile

The technical requirements of the present document apply under the environmental profile for operation of the equipment, which shall be in accordance with its intended use. The equipment shall comply with all the technical requirements of the present document at all times when operating within the boundary limits of the operational environmental profile defined by its intended use.

4.2 General performance criteria

For the purpose of the receiver performance tests, the receiver shall produce a raw data signal with a Bit Error Ratio (BER) of 10^{-3} without correction after demodulation.

NOTE 1: Bit error ratio can be computed from the Message Success Ratio (MSR) by the expression:

$$\text{MSR} = (1-p)^n$$

where p is the probability of single bit error (10^{-3}) and n the number of bits in the message.

NOTE 2: Some designs may include permanent channel coding as an integral part of information transmission. Such designs may not be able to operate without correction inherent in the channel coding. For the purposes of receiver test suites in the present document, the wanted performance criteria are specified with optional FEC and/or ARQ mechanisms disabled.

4.3 Requirements for transmitters

4.3.1 Frequency error

4.3.1.1 Applicability

The frequency error requirement shall apply to all types of equipment.

4.3.1.2 Description

Frequency error is the difference between the measured centre frequency and the nominal operating frequency.

4.3.1.3 Limits

The centre frequency error shall not exceed the frequency drift range given in Table 4.3.1.3-1.

Table 4.3.1.3-1: Frequency error

Equipment Types	Frequency drift range (ppm)
Type 1	±20 ppm
Type 2	±20 ppm
Type 3	±20 ppm

4.3.1.4 Conformance

The conformance test for frequency error requirement shall be as defined in clause 5.3.1 of the present document.

4.3.2 Effective radiated power

4.3.2.1 Applicability

The effective radiated power requirement shall apply to all types of equipment.

4.3.2.2 Description

The effective radiated power (e.r.p.) is the power radiated in the direction of the maximum field strength under specified conditions of measurements for any condition of modulation.

4.3.2.3 Limits

The effective radiated power shall not exceed the maximum radiated power limit of 25 mW.

4.3.2.4 Conformance

The conformance tests for this requirement shall be as defined in clause 5.3.2 of the present document.

4.3.3 Occupied bandwidth

4.3.3.1 Applicability

The occupied bandwidth requirement shall apply to all types of equipment.

4.3.3.2 Description

Occupied BandWidth (OBW) is the width of the band of frequencies that contain 99 % of the power of the signal.

4.3.3.3 Limits

The occupied bandwidth shall be greater than or equal to 600 kHz and not exceed 1 MHz.

The lower and upper edges of the occupied bandwidth do not overlap with another operating channel.

The centre frequency shall be no closer than 500 kHz from the permitted frequency band edge.

4.3.3.4 Conformance

The conformance tests for this requirement shall be as defined in clause 5.3.3 of the present document.

4.3.4 Transmitter spectrum emission mask

4.3.4.1 Applicability

The transmitter spectrum emission mask shall apply to all types of equipment.

4.3.4.2 Description

Transmitter spectrum mask apply at the frequency ranges in terms of frequency offset to centre frequency specified in Table 4.3.4.3-1.

4.3.4.3 Limits

The absolute power limits given in Table 4.3.4.3-1 and in Figure 4.3.4.3-1 shall not be exceeded.

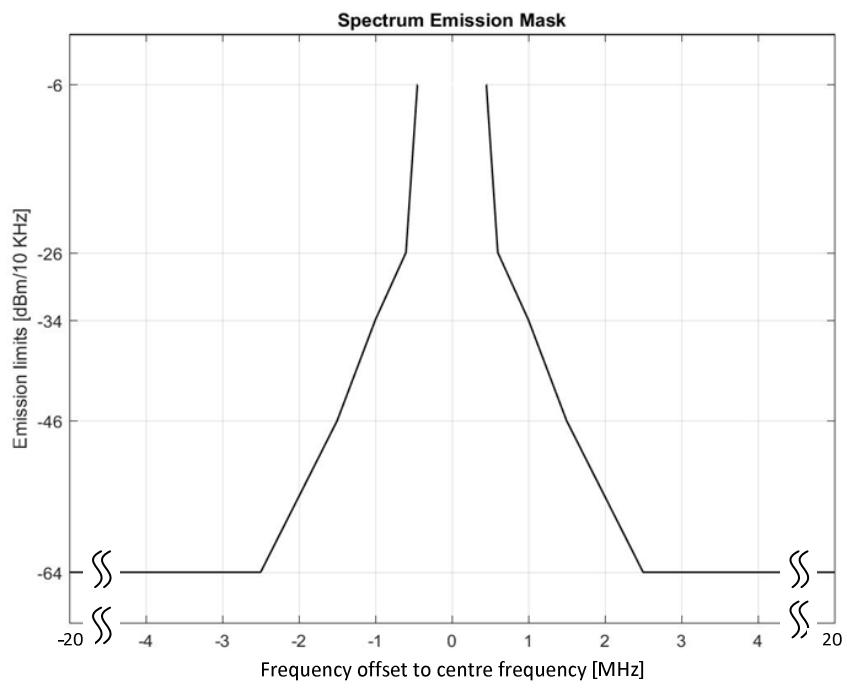

Figure 4.3.4.3-1: Transmitter spectrum emission mask

Table 4.3.4.3-1: Transmitter spectrum emission mask

Frequency offset to centre frequency	±0,45 MHz offset	±0,6 MHz offset	±1,0 MHz offset	±1,5 MHz offset	±2,5 to ±20 MHz Offset
Emission limit (dBm)	-6	-26	-34	-46	-64
Reference Bandwidth	10 kHz	10 kHz	10 kHz	10 kHz	10 kHz

NOTE: This specific stringent mask is based on the ECC Reports 261 [i.4] and 246 [i.5].

4.3.4.4 Conformance

The conformance tests for this requirement shall be as defined in clause 5.3.4 of the present document.

4.3.5 Transmitter unwanted emissions in the spurious domain

4.3.5.1 Applicability

The transmitter unwanted emissions requirement shall apply to all types of equipment.

4.3.5.2 Description

Transmitter unwanted emissions in the spurious domain are emissions at all frequencies apart from the operating channel and outside of the frequency ranges specified in the spectrum emission mask given in Table 4.3.4.3-1.

4.3.5.3 Limits

Transmitter unwanted emissions in the spurious domain shall be as specified in Table 4.3.5.3-1 outside of the frequency ranges specified in the spectrum emission mask given in Table 4.3.4.3-1.

**Table 4.3.5.3-1: Transmitter unwanted emission limits in the spurious domain
(see ERC/REC 74-01 [i.9])**

Frequency range	Maximum power	Reference Bandwidth
$87,5 \text{ MHz} \leq f < 118 \text{ MHz}$	-54 dBm	100 kHz
$174 \text{ MHz} \leq f < 230 \text{ MHz}$	-54 dBm	100 kHz
$470 \text{ MHz} \leq f < 694 \text{ MHz}$	-54 dBm	100 kHz
$30 \text{ MHz} \leq f < 1 \text{ GHz}$ (except above frequency bands)	-36 dBm	100 kHz
$1 \text{ GHz} \leq f \leq 6 \text{ GHz}$	-30 dBm	1 MHz

NOTE: Parts of unwanted emissions in the spurious domain are covered by the limits defined in Table 4.3.4.3-1.

4.3.5.4 Conformance

The conformance tests for this requirement shall be as defined in clause 5.3.5 of the present document.

4.3.6 Duty cycle

4.3.6.1 Applicability

The duty cycle requirement shall apply to all types of equipment.

4.3.6.2 Description

Duty cycle describes the behaviour of transmissions within the duty cycle observation bandwidth over the duty cycle observation period.

Each transmission consists of an RF emission, or a sequence of RF emissions.

4.3.6.3 Limits

The duty cycle values shall comply with the limits defined in Table 4.3.6.3-1.

Table 4.3.6.3-1: Duty Cycle Parameters

Parameter	Value
Duty cycle observation bandwidth	Permitted frequency band
Duty cycle observation period	3 600 seconds
Maximum duty cycle	10 %
NOTE: The frequency band is defined in Table 1-1.	

4.3.6.4 Conformance

Conformance with the duty cycle requirement shall be as defined in clause 5.3.6 of the present document.

4.3.7 Transient power

4.3.7.1 Applicability

The transient power requirement shall apply to all types of equipment.

4.3.7.2 Description

Transmitter transient power is power falling into frequencies other than the operating channel as a result of the transmitter being switched on and off.

4.3.7.3 Limits

The transient power shall not exceed the limits given in Table 4.3.7.3-1.

Table 4.3.7.3-1: Transmitter transient power limits

Absolute frequency offset from nominal operating frequency	RBW _{REF}	Peak power limit
< 600 kHz	1 kHz	0 dBm
≥ 600 kHz	1 kHz	-27 dBm

4.3.7.4 Conformance

The conformance test suite for the transient power requirement shall be as defined in clause 5.3.7 of the present document.

4.4 Requirements for receivers

4.4.1 Receiver sensitivity

4.4.1.1 Applicability

The receiver sensitivity requirement shall apply to all types of equipment.

4.4.1.2 Description

The receiver sensitivity is the minimum signal power input to the receiver which produces the general performance criterion stated in clause 4.2.

4.4.1.3 Limits

The sensitivity for receivers shall be below or equal to Table 4.4.1.3-1 level.

Table 4.4.1.3-1: Limits for Receiver sensitivity

Receiver Sensitivity S	
$S = 10 \log_{10} \left(\frac{R}{R_0} \right) - 87 \text{ dBm}$ when $R \leq 1 \text{ Mbps}$	
$S = 20 \log_{10} \left(\frac{R}{R_0} \right) - 87 \text{ dBm}$ when $R > 1 \text{ Mbps}$	
where:	
<ul style="list-style-type: none"> • S is the sensitivity in dBm; • R is the EUT data rate in kbps; • R₀ is 150 kbps. 	

NOTE: For systems with high spectrum efficiency with $R > 1 \text{ Mbps}$, higher sensitivity level is needed to support more advanced coding and modulation scheme.

4.4.1.4 Conformance

The conformance tests for this requirement shall be as defined in clause 5.4.1.

4.4.2 Adjacent channel selectivity

4.4.2.1 Applicability

The adjacent channel selectivity requirement shall apply to all types of equipment.

4.4.2.2 Description

Adjacent channel selectivity is a measure of the receiver capability to receive a wanted modulated signal without exceeding the general performance criteria stated in clause 4.2 of the present document due to the presence of an unwanted input signal in the adjacent channels.

4.4.2.3 Limits

The adjacent channel selectivity shall not be less than the value specified in Table 4.4.2.3-1.

Table 4.4.2.3-1: Adjacent channel selectivity limit

Parameter	Value
	Wanted signal = S+3 dB
Adjacent channel selectivity	-65 dBm

4.4.2.4 Conformance

The conformance test suite for the adjacent channel selectivity requirement shall be as defined in clause 5.4.2 of the present document.

4.4.3 Receiver spurious response rejection

4.4.3.1 Applicability

The receiver spurious response rejection requirement shall apply to all types of equipment.

4.4.3.2 Description

The spurious response rejection is a measure of the capability of the receiver to receive a wanted signal without exceeding a given degradation due to the presence of an unwanted signal at any frequency at which a response is obtained. The frequencies of the adjacent signals (channels) are excluded.

4.4.3.3 Limits

The spurious response rejection of the equipment shall be equal to or greater than the limit in Table 4.4.3.3-1.

Table 4.4.3.3-1: Limits for Receiver Spurious Response Rejection

Spurious response frequency offset from nominal operating frequency	Limit
-20 MHz to -2 MHz and 2 MHz to 20 MHz	-49 dBm

4.4.3.4 Conformance

The conformance test suite for the receiver spurious response rejection requirement shall be as defined in clause 5.4.3 of the present document.

4.4.4 Blocking

4.4.4.1 Applicability

The blocking requirement shall apply to all types of equipment.

4.4.4.2 Description

Blocking is a measure of the receiver capability to receive a wanted modulated signal without exceeding a given degradation due to the presence of an unwanted input signal at any frequencies other than those of the spurious responses or the adjacent channels or bands.

4.4.4.3 Limits

The blocking level shall not be less that value given in Table 4.4.4.3-1.

Table 4.4.4.3-1: Blocking level parameters for wideband SRD

Frequency offset from nominal operating frequency	Limits
	Wanted signal = S+3 dB
±2 MHz	≥ -49 dBm
±10 MHz	≥ -30 dBm

4.4.4.4 Conformance

The conformance test suite for the blocking requirement shall be as defined in clause 5.4.4 of the present document.

4.4.5 Receiver spurious emission

4.4.5.1 Applicability

The receiver spurious emission requirement shall apply to all types of equipment.

4.4.5.2 Description

Spurious emission from the receiver are components, at any frequency, radiated by the equipment and antenna.

4.4.5.3 Limits

The power of any spurious emission, radiated or conducted, shall not exceed the values given in Table 4.4.5.3-1.

Table 4.4.5.3-1: Receiver Spurious Emission Limits

Frequency range	Maximum Power (e.r.p.)
30 to 1 000 MHz	-57 dBm
1 000 to 6 000 MHz	-47 dBm

4.4.5.4 Conformance

The conformance test suite for the receiver spurious radiations requirement shall be as defined in clause 5.4.5 of the present document.

4.4.6 Receiver maximum input signal level

4.4.6.1 Applicability

The receiver maximum input signal level requirement shall apply to all types of equipment.

4.4.6.2 Description

Maximum input signal level is the maximum signal power input to the receiver which produces the general performance criterion stated in clause 4.2. The test input signal is generated at the nominal operating frequency and modulated with normal modulation.

4.4.6.3 Limits

The measured maximum input signal level shall not be less than the limits given in Table 4.4.6.3-1.

Table 4.4.6.3-1: Limits for receiver maximum input signal level

Parameter	Limit
Rx maximum input signal level	-30 dBm

4.4.6.4 Conformance

The conformance test suite for the receiver maximum input signal level requirement shall be as defined in clause 5.4.6 of the present document.

4.5 Requirements for spectrum access

4.5.1 Clear channel assessment threshold

4.5.1.1 Applicability

The clear channel assessment threshold requirement shall apply to all types of equipment.

4.5.1.2 Description

CCA threshold is the received signal level above which the receiver determines that the operating channel is not available for use. The operating channel is busy if the received signal is greater than or equal to the CCA threshold; otherwise the channel is free.

4.5.1.3 Limits

The CCA threshold shall not exceed the limits given in Table 4.5.1.3-1.

Table 4.5.1.3-1: CCA threshold limit

Parameter	Value
CCA threshold	-75 dBm

4.5.1.4 Conformance

The conformance test suite for the clear channel assessment threshold requirement shall be as defined in clause 5.5.1 of the present document.

4.5.2 Listen Before Talk (LBT)

4.5.2.1 Applicability

The listen before talk requirement shall apply to all transmitters.

4.5.2.2 Description

In order to make maximum use of the available channels, an equipment uses a Listen Before Talk (LBT) protocol.

A device uses LBT to determine whether the intended channel is available for transmitting a message that is not a short response message. The device is not required to use LBT for transmitting a short response message

A short response message is a message that is sent in response to a message received from another transmitting device. The short response message is beneficial for the transmitting device to determine whether the transmitted message has been successfully received and hence avoiding unnecessary retransmissions. A short message is considered to be a response to a message received from another transmitting device if the interval separating the two messages does not exceed the T_{MRI} parameter and the duration of the short message does not exceed the T_{MRD} parameter. A polite equipment that intends to transmit a message, which is not a short response message uses a Listen Before Talk (LBT) protocol as described below.

A device senses the channel for a total listening time, T_L , which consists of a fixed listening time, T_F , and an additional pseudo random listening time, T_{PS} , as follows:

- The fixed listening time, T_F , is the minimum contiguous time that the equipment listens for a received signal immediately prior to transmission to determine whether the intended channel is free (see clause 4.5.1).
- The pseudo random listening time, T_{PS} , shall be a random value selected between 0 and T_{PS_MAX} following a uniform distribution:
 - The device randomly selects a new T_{PS} every time it intends to transmit a message that is not a short response message.
- If the channel is free at the beginning of the T_L and remains free throughout T_F then the device:
 - Counts down T_{PS} during the time that the channel remains free and T_{PS} is greater than 0.
 - Proceeds with the transmission if T_{PS} is equal to 0.

If during the listening mode another transmission is detected on the intended channel then the T_{PS} countdown is suspended and the listening time shall commence from the instant that the intended channel is free again and using a T_L that equal to the sum of T_F and the previous T_{PS} value when it was suspended.

4.5.2.3 Limits

Parameters for spectrum access shall comply to the limits specified in Table 4.5.2.3-1.

Table 4.5.2.3-1: Reference limits for spectrum access timing parameters

Parameter	Limit	Notes
CCA interval	160 μ s	Minimum value of the CCA interval.
Fixed listening time (T_F)	\geq CCA interval	Minimum time that the equipment listens for a received signal.
Pseudo random listening time (T_{PS})	$0 \leq T_{PS} \leq T_{PS_MAX}$	Additional pseudo random time that the equipment listens for a received signal.
Maximum pseudo random listening time (T_{PS_MAX})	> 0	Maximum T_{PS} value, in microseconds.
Maximum response interval (T_{MRI})	\leq CCA interval	Interval between the end of the transmission and the start of the short message in a dialog.
Maximum response duration (T_{MRD})	≤ 28 ms	Maximum duration of any short message.

4.5.2.4 Conformance

The conformance test suite for LBT shall be as defined in clause 5.5.2 of the present document.

4.6 Functional Requirements

4.6.1 Master Network Access Point

4.6.1.1 Applicability

The master network access point requirement shall only apply to Type 2 equipment.

4.6.1.2 Description

A master NAP is scheduling the periodic transmission of signals for mobile terminal nodes and nomadic devices to detect whether they are within the coverage of the master NAP. These signals may contain additional information, such as network configuration, operation parameters, etc.

4.6.1.3 Limits

The periodicity of transmitting signals as described in clause 4.6.1.2 shall not exceed 900 seconds.

4.6.1.4 Conformance

The conformance test suite for master NAP shall be as defined in clause 5.6.1 of the present document.

4.6.2 Network Access Point

4.6.2.1 Applicability

The Network Access Point (NAP) requirement shall apply to all types of equipment.

4.6.2.2 Description

The equipment shall provide a means for terminal nodes in a data network to communicate with a network or service outside the data network.

Messages to be transferred via the NAP may originate within or outside the data network. Once received by the NAP, such messages shall be transferred to the intended destination.

The delay between the message transfer request received by the NAP and the transfer of the message by the NAP to its intended destination is the NAP message transit delay.

NOTE: The mechanisms used to transfer the messages are outside the scope of the present document. For example, messages may be re-transmitted as received, may be transformed into different protocol encapsulations, or may be translated in any manner required by the equipment under test, and may be transmitted reliably or unreliably.

4.6.2.3 Limits

The NAP message transit delay shall not exceed the value of 60 minutes.

4.6.2.4 Conformance

The conformance test suite for the Network Access Point requirement shall be as defined in clause 5.6.2 of the present document.

5 Testing for compliance with technical requirements

5.1 Environmental conditions for testing

Tests defined in the present document shall be carried out at representative points within the boundary limits of the operational environmental profile defined by its intended use.

Where technical performance varies subject to environmental conditions, tests shall be carried out under a sufficient variety of environmental conditions (within the boundary limits of the operational environmental profile defined by its intended use) to give confidence of compliance for the affected technical requirements.

5.2 General conditions for testing

5.2.1 General considerations

Technical documentation and operating manuals, sufficient to allow testing to be performed, shall be provided along with the EUT and any companion equipment necessary for normal operation of the EUT for its intended use. Annex F identifies various EUT properties required by the test suites specified in the present document.

5.2.2 Presentation of equipment for testing purposes

5.2.2.1 General Considerations

Measurements shall be performed, according to the present document, on samples of equipment defined in clauses 5.2.2.2 to 5.2.2.3.

5.2.2.2 Choice of model for testing

5.2.2.2.1 General considerations

One or more samples of the EUT, as needed, shall be tested.

EUT shall be tested complete with any ancillary equipment needed for testing.

If an EUT has separate power modules or ancillary equipment required for normal operation, each combination shall be tested with the EUT.

All necessary test signal sources special to the equipment and set-up information shall accompany the equipment when it is submitted for testing.

5.2.2.2.2 EUT with an external RF connector

EUT with an external RF connector offered for testing shall provide a 50 Ω connector for conducted RF power measurements.

5.2.2.2.3 EUT without an external RF connector

5.2.2.2.3.1 General Considerations

Conducted measurements on an EUT with an integral antenna or with an antenna connection other than a 50 Ω coaxial connector may be made by:

- access to an internal connector; or
- use of a test fixture if access to an internal connector is not available.

5.2.2.2.3.2 EUT with an internal connector

Where the EUT has an internal conventional 50 Ω coaxial connector between the antenna and the circuitry, this may be utilized to perform conducted measurements. The means to access the connector, with the aid of a diagram, shall be stated by the manufacturer.

Use of an internal antenna connection shall be recorded in the test report.

5.2.2.2.3.3 Use of a Test Fixture

A test fixture is a structure for coupling an EUT with an integral antenna, at all frequencies for which measurements need to be performed, to a 50 Ω RF terminal.

A test fixture may only be used for relative measurements.

For further information on the test fixture, see Annex E.

5.2.2.3 Testing of modular equipment

If a family of equipment has alternative output power levels provided by the use of separate power modules or add on stages, or additionally has alternative frequency coverage, then each module or add on stage shall be tested in combination with the EUT over each applicable frequency range.

5.2.3 Test power source

5.2.3.1 General

The equipment shall be tested using the appropriate test power source as specified in clause 5.2.3.2 or 5.2.3.3. Where equipment is intended to be powered using either external or internal power sources, then the equipment shall be tested using the external power source as specified in clause 5.2.3.2 then repeated using the internal power source as specified in clause 5.2.3.3.

The test power source used shall be stated in the test report.

5.2.3.2 External test power source

External test power sources shall be capable of producing test voltages as specified in the environmental profile. The internal impedance of the external test power source shall be low enough for its effect on the test results to be negligible. For the purpose of the tests, the voltage of the external test power source shall be measured at the input terminals of the equipment. Note that this may be the mains connection point for equipment supplied with an external power supply. The external test power source shall be de-coupled and applied immediately at the equipment battery terminals as practicable. For radiated measurements, any external power cable shall be equipped with ferrite bead which shall present an impedance of at least 100 Ω at 100 MHz.

5.2.3.3 Internal test power source

For radiated measurements on portable equipment with integral or dedicated antenna, fully charged internal batteries shall be used. The batteries used shall be as supplied or recommended by the manufacturer. If internal batteries are used, at the end of each test the voltage shall be within 5 % of the voltage at the beginning of each test. Where this is not appropriate, clause B.4.2 applies.

5.2.4 Thermal test conditions

Before measurements are made the equipment shall have reached thermal balance in the test chamber. The equipment shall be switched off during the temperature stabilizing period.

In the case of equipment containing temperature stabilization circuits designed to operate continuously, the temperature stabilization circuits shall be powered on for 15 minutes after thermal balance has been obtained, and the equipment shall then meet the specified requirements.

If the thermal balance is not checked by measurements, a temperature stabilizing period of one hour, shall be allowed. The sequence of measurements shall be chosen, and the humidity content in the test chamber shall be controlled so that condensation does not occur.

5.2.5 Conducted measurements

5.2.5.1 Artificial antenna

Conducted tests shall be carried out using an artificial antenna which shall be a 20 dB attenuator connected to the EUT antenna connector and providing a 50 Ω output or connection to test equipment.

NOTE: 20 dB attenuator protects test equipment as the maximum power will never exceed 7 dBm at its input connector.

5.2.6 Radiated measurements

For all radiated measurements a suitable test site, selected from those described in clause B.2, and applicable measurement procedures, as described in each conformance test suite, shall be used.

When performing radiated transmitter measurements, the EUT shall be configured, and antenna(s) positioned (including smart antenna systems and systems capable of beam forming) and oriented for maximum radiated power into the measuring antenna. The measuring antenna shall use the same polarization as the EUT and be chosen according to the frequency of the transmitter.

When performing radiated receiver measurements, the EUT shall be configured, and antenna(s) positioned (including smart antenna systems and systems capable of beam forming) for maximum sensitivity towards the test antenna. The test antenna shall use the same polarization as the EUT and be chosen according to the frequency of the transmitter.

5.2.7 Applicable measurement methods

Although the measurement methods in the present document allow conducted measurements to be performed, the EUT together with all its intended antenna assemblies shall comply with the applicable technical requirements.

Selection of test method is described in clause 5.2.2.2 conditions. Where a test method specifies a radiated measurement, it is not generally possible to substitute a conducted or a test fixture measurement.

A summary of the applicable measurement methods for each test suite are shown in Table 5.2.7-1.

Table 5.2.7-1: Applicable test methods

Clause	Description	Conducted measurement for EUT with connector	Radiated measurement for EUT with antenna	Test Fixture for EUT with integral antenna for relative measurement
5.3.1	Transmitter frequency error	Yes	Yes	Yes
5.3.2	Effective radiated power	Yes	Yes	See note
5.3.3	Occupied bandwidth	Yes	Yes	Yes
5.3.4	Transmitter spectrum emission mask	Yes	Yes	See note
5.3.5	Transmitter unwanted emission in the spurious domain	Yes	Yes	No
5.3.6	Duty cycle	Yes	Yes	Yes
5.3.7	Transient Power	Yes	Yes	No
5.4.1	Receiver sensitivity	Yes	Yes	No
5.4.2	Adjacent Channel Selectivity	Yes	Yes	No
5.4.3	Receiver spurious response rejection	Yes	Yes	No
5.4.4	Blocking	Yes	Yes	No
5.4.5	Receiver spurious emission	Yes	Yes	No
5.4.6	Receiver maximum input signal level	Yes	Yes	No
5.5.1	CCA threshold	Yes	Yes	No
5.5.2	Listen before talk	Yes	Yes	No
5.6.1	Master Network Access Point	Yes	Yes	Yes
5.6.2	Network Access Point	Yes	Yes	Yes
NOTE:	When the environmental profile requires extreme temperature testing, the difference between a radiated measurement and a test fixture measurement under normal test conditions may be used as a correction for a test fixture measurement made under extreme test conditions.			

If the EUT has more than one antenna port, e.g. separate antennas for Tx and Rx or separate antennas for different operating frequencies or diversity antennas, then:

- If every antenna port has a 50 Ω connector, conducted measurements may be performed. All the antenna ports shall be terminated in 50 Ω connections as described in clause 5.2.5.1.
- Otherwise only radiated measurements shall be performed. All antenna ports shall be fitted with an antenna representative of normal use.

5.2.8 Test signals for data

For the purposes of the present document a test signal is a modulated or unmodulated carrier generated by the EUT to facilitate a particular test. The EUT should be capable of generating the following test signals:

- D-M1: A test signal consisting of an unmodulated carrier. This test signal is optional but helps to simplify some tests.
- D-M2: A test signal consisting of a modulated carrier representative of normal operation and generating the greatest occupied RF bandwidth. The preferred test signal consists of a pseudo-random bit sequence of at least 511 bits in accordance with Recommendation ITU-T O.153 [i.6]. This sequence shall be continuously repeated.
- D-M2a: A test signal as described in D-M2 but generated intermittently. The generated RF signals shall be the same for each transmission except for the data sequence, occur regularly in time, be accurately repeatable and their timing duration shall represent normal operation of the EUT except for compliance with a duty cycle limit.
- D-M3: A test signal representative of normal operation of the EUT. The test signal may be formatted and may contain error detection and correction.

Test signals may be generated by applying baseband signals to a modulation port on test equipment for receivers or be generated internally by equipment for transmitters. Operation in a test mode may involve suitable temporary internal modifications of the equipment under test or the use of special software. Details of the method employed shall be recorded in the test report.

For each test performed, the test signal used shall be recorded in the test report. Permitted test signals for each test are shown in Table 5.2.8-1.

Table 5.2.8-1: Permitted test signals

Clause	Description	Test Signal
5.3.1	Transmitter frequency error	D-M1 if available otherwise D-M2 if available otherwise, D-M2a if available otherwise, D-M3
5.3.2	Effective radiated power	D-M2 if available otherwise, D-M2a if available otherwise, D-M3
5.3.3	Occupied bandwidth	D-M2 if available otherwise, D-M2a if available otherwise, D-M3
5.3.4	Transmitter spectrum emission mask	D-M2 if available otherwise, D-M2a if available otherwise, D-M3
5.3.5	Transmitter unwanted emission in the spurious domain	D-M2 if available otherwise, D-M2a if available otherwise, D-M3
5.3.6	Duty cycle	D-M3
5.3.7	Transient Power	D-M3
5.4.1	Receiver sensitivity	D-M3
5.4.2	Adjacent Channel Selectivity	D-M3
5.4.3	Receiver spurious response rejection	D-M3
5.4.4	Blocking	D-M3
5.4.5	Receiver spurious emission	D-M3
5.4.6	Receiver maximum input signal level	D-M3
5.5.1	CCA threshold	D-M3
5.5.2	Listen before talk	D-M3
5.6.1	Master Network Access Point	D-M3
5.6.2	Network Access Point	D-M3

5.2.9 Measuring receiver

5.2.9.1 Description

The term "measuring receiver" refers to a frequency-selective voltmeter or a spectrum analyser. Unless stated otherwise, an RMS detector shall be used.

5.2.9.2 Reference bandwidth

If not otherwise specified in the measurement procedure, the resolution bandwidth of the measuring receiver (RBW_{measured}) should be equal to the reference bandwidth (RBW_{REF}) given in Table 5.2.9.2-1.

Table 5.2.9.2-1: Reference bandwidth for the measurement receiver

Frequency range: (f)	Measuring receiver resolution bandwidth (RBW _{REF})
f < 150 kHz	200 Hz or 300 Hz
150 kHz ≤ f < 25 MHz	9 kHz or 10 kHz
25 MHz ≤ f ≤ 1 000 MHz	100 kHz or 120 kHz
f > 1 000 MHz	1 MHz
NOTE: The frequency ranges and corresponding RBW _{REF} values are derived from EN 55016-1-1 [i.10].	

To extract the signal from noise floor, test equipment RBW used for the measurement (RBW_{measured}) may be different from RBW_{REF}. but a correction shall be applied before to compare power levels to limits:

When RBW_{measured} < RBW_{REF} the result should be integrated over RBW_{REF} for instance according to the formula (1):

$$B = 10 \log \left(RBW_{REF} * \frac{\left(\frac{1}{n} \right) * \sum_{i=1}^n \left(10^{\left(\frac{P(i)}{10} \right)} \right)}{RBW_{MEASURED}} \right) \quad (1)$$

Where:

- P(i) are the measured samples with RBW_{measured};
- n is the number of samples inside RBW_{REF};
- B is the corresponding value at RBW_{REF}.

When RBW_{measured} > RBW_{REF} the result for broadband emissions should be normalized to the bandwidth Ratio according to the formula (2):

$$B = A + 10 \log \frac{RBW_{ref}}{RBW_{MEASURED}} \quad (2)$$

Where:

- A is the measured value at the wider measurement bandwidth RBW_{measured};
- B is the corresponding value at RBW_{REF}.

For discrete emissions, defined as a narrow peak with a level of at least 6 dB above the average level inside the measurement bandwidth, the above correction is not applicable while integration over RBW_{REF} is still applicable.

5.3 Conformance methods of measurement for transmitters

5.3.1 Frequency error

5.3.1.1 Test conditions

- 1) The measurement shall be performed on the EUT set to the nominal operating frequency.
- 2) If D-M1 test signal is available (unmodulated carrier), measurement shall be performed according to clause 5.3.1.4.
- 3) For all other test signals from clause 5.2.8, Table 5.2.8-1, measurement shall be performed according to clause 5.3.1.5.

- 4) An EUT without a permanent or temporary antenna connector shall be tested according to clause 5.3.1.3.
- 5) An EUT with a permanent or temporary antenna connector shall be tested according to clause 5.3.1.2.

5.3.1.2 Radiated measurement

The EUT shall be tested according to clause 5.2.6. The measurement procedure in clause 5.3.1.4 if D-M1 signal is available or clause 5.3.1.5 otherwise should be performed.

5.3.1.3 Conducted measurement

The EUT shall be connected to the spectrum analyser. The measurement procedure in clause 5.3.1.4 if D-M1 signal is available or clause 5.3.1.5 otherwise should be performed.

5.3.1.4 Measurement procedure for D-M1 test signal

- 1) The measurement shall be performed with an unmodulated carrier test signal (D-M1).

Step 1:

Operation of the EUT shall be started on the nominal operating frequency at 25 °C temperature condition.

The frequency of the unmodulated carrier (N) shall be measured and noted.

Step 2:

Operation of the EUT shall be started on the nominal operating frequency from 25 °C to lower temperature and extreme voltage conditions from the environmental profile.

The frequency of the unmodulated carrier (A) shall be measured and noted.

Step 3:

Operation of the EUT shall be started on the nominal operating frequency from 25 °C to the higher temperature and extreme voltage conditions from the environmental profile.

The frequency of the unmodulated carrier (B) shall be measured and noted.

The information shown in Table 5.3.1.4-1 shall be recorded in the test report for each test condition.

Table 5.3.1.4-1: Information Recorded in the Test Report for Frequency Error Measurement using unmodulated carrier

Value	Notes
Test signal	The test signal used. See clause 5.2.8, Table 5.2.8-1
EUT nominal operating frequency (F)	F
Measured centre Frequency (N)	Measured unmodulated carrier frequency at 25 °C
Measured centre frequency (A) under lower test conditions from environmental profile	Measured unmodulated centre frequency
Measured centre frequency (B) under higher test conditions from environmental profile	Measured unmodulated centre frequency
Maximum frequency error over environmental profile	Maximum of absolute value of N-F, A-F and B-F

5.3.1.5 Measurement procedure for other test signal

- 1) The measurement shall be performed with modulated carrier test signal according to clause 5.2.8, Table 5.2.8-1.

Step 1:

Operation of the EUT shall be started on the nominal operating frequency.

Step 2:

Occupied Bandwidth (OBW) frequency edges $FOBW_{low}$ and $FOBW_{high}$ are measured over the full range of temperature and voltage conditions from the environmental profile. Compute the centre frequency of the occupied bandwidth as $(FOBW_{low} + FOBW_{high})/2$.

CF_{low} is the lowest centre frequency of measured OBW over full environmental profile.

CF_{high} is the highest centre frequency of measured OBW over full environmental profile.

The information shown in Table 5.3.1.5-1 shall be recorded for each operating channel.

Table 5.3.1.5-1: Information Recorded in the Test Report for Frequency Error Measurement using modulated signal

Value	Notes
Test signal	The test signal used. See clause 5.2.8, Table 5.2.8-1
EUT channel nominal frequency (F)	Nominal frequency. See Annex F
CF_{low}	Lowest centre frequency of measured OBW over full environmental profile
CF_{high}	Highest centre frequency of measured OBW over full environmental profile
Maximum frequency error over environmental profile	Maximum of absolute value of $(CF_{low} - F)$ and $(CF_{high} - F)$

5.3.2 Effective radiated power

5.3.2.1 Effective Radiated Power (conducted measurement)

5.3.2.1.0 General

This method applies only to EUT with a permanent external antenna connector.

5.3.2.1.1 Test conditions

- 1) The measurement shall be performed at the EUT set to the nominal operating frequency.
- 2) The EUT transmitter shall be switched on, the measuring receiver shall be tuned to the frequency of the transmitter under test. Test signal specified in clause 5.2.8, Table 5.2.8-1 shall be used.
- 3) Span of the spectrum analyser shall be the Permitted Frequency Band.
- 4) The RBW of the spectrum analyser shall be wide enough to cover the complete power envelope (\geq OCW) of the signal of the EUT.

5.3.2.1.2 Measurement procedure

The antenna port of the EUT shall be connected to a 20 dB attenuator and the output of the attenuator connected to the measuring receiver.

The information shown in Table 5.3.2.1.2-1 shall be recorded in the test report.

Table 5.3.2.1.2-1: Information Recorded in the Test Report for Effective Radiated Power (Conductive)

Value	Notes
Test environment	Normal operation or unmodulated carrier
Nominal operating frequency	
Measured Effective Radiated Power	Maximum measured conducted power value adjusted by the antenna gain (relative to a dipole)

5.3.2.2 Effective radiated power (radiated measurement)

5.3.2.2.0 General

This measurement method applies to EUT other than those measured using clause 5.3.2.1.

5.3.2.2.1 Test conditions

- 1) The measurement shall be performed on the EUT set to the nominal operating frequency. These measurements shall be performed at the highest power level at which EUT is intended to operate.
- 2) The EUT shall be switched on, if D-M1 is available, and the measuring receiver shall be tuned to the nominal operating frequency of EUT. D-M1 test signal (unmodulated carrier) shall not be used for equipment with non-constant envelope modulation.
- 3) Span of the spectrum analyser shall be the Permitted Frequency Band.
- 4) The RBW of the spectrum analyser shall be wide enough to cover the complete power envelope (\geq OCW) of the signal of the EUT. VBW shall be the nearest setting to 3 x RBW.
- 5) In the case of a removable antenna, the antenna shall be fitted in a manner representative of intended use.

5.3.2.2.2 Measurement procedure

A test site is selected from those described in clause B.2 based on the guidance in clause B.7 and the radiated power established using the procedures described in clause B.6.2 (or clause B.6.3) depending on the test site, followed by clause B.6.4.

In the case of non-constant envelope modulation, a peak detector shall be used.

The information shown in Table 5.3.2.2.2-1 shall be recorded in the test report.

Table 5.3.2.2.2-1: Information Recorded in the Test Report for Effective Radiated Power (Radiated)

Value	Notes
Test environment	Normal operation or unmodulated carrier
Nominal operating frequency	
Measure of Effective Radiated Power	Larger value from horizontal and vertical measurement equivalent radiated power, plus equipment antenna gain

5.3.3 Occupied bandwidth

5.3.3.1 Test conditions

- 1) The measurement shall be performed at the EUT set to the nominal operating frequency.
- 2) The measurement shall be performed with a spectrum analyser.
- 3) An EUT without a permanent or temporary antenna connector shall be tested according to clause 5.3.3.2.
- 4) An EUT with a permanent or temporary antenna connector shall be tested according to clause 5.3.3.3.

5.3.3.2 Radiated measurement

A test site is selected from those described in clause B.2 based on the guidance in clause B.7 and the measurements in clause 5.3.3.4 shall be performed using corresponding radiated measurement methods described in clause B.6.

5.3.3.3 Conducted measurement

The EUT shall be connected to an artificial antenna which shall be connected to the spectrum analyser.

The measurements in clause 5.3.3.4 shall be performed.

5.3.3.4 Measurement procedure

The spectrum analyser shall be configured for the parameters shown in Table 5.3.3.4-1.

Table 5.3.3.4-1: Test Parameters for Max Occupied Bandwidth Measurement

Setting	Value	Notes
Centre frequency	Nominal operating frequency	
RBW	1 % to 3 % of OCW without being below 100 Hz	
VBW	3 x RBW	Nearest available analyser setting to 3 x RBW
Span	At least 2 x Operating Channel width	Span should be large enough to include all major components of the signal and its side bands
Detector Mode	RMS	
Trace	Max hold	

Step 1:

Operation of the EUT shall be started, on the he EUT nominal operating frequency with test signal selected in accordance with clause 5.2.8.

The signal attenuation shall be adjusted to ensure that the -23 dBc-points are at least 5 dB above the noise floor of the analyser to avoid the noise signals on either side of the power envelope being included in the measurement.

Step 2:

When the trace is completed the peak value of the trace shall be located and the analyser marker placed on this peak.

Step 3:

The 99 % occupied bandwidth function of the spectrum analyser shall be used to measure the occupied bandwidth of the signal. When the 99 % occupied bandwidth function is not available, OBW is the range between the two measurement points at -23 dB below the maximum emission level. Occupied bandwidth frequency edges $FOBW_{low}$ and $FOBW_{high}$ shall be measured.

The information shown in Table 5.3.3.4-2 shall be recorded for each nominal operating frequency and over the full environmental profile.

Table 5.3.3.4-2: Information Recorded in the Test Report for Occupied Bandwidth

Value	Notes
Nominal operating frequency for channel n	Nominal operating frequency tested
Instantaneous occupied bandwidth value (OBW)	The value measured with the spectrum analyser
Lower frequency edge ($FOBW_{low}$) for channel n	The value measured with the spectrum analyser
Upper frequency edge ($FOBW_{high}$) for channel n	The value measured with the spectrum analyser
Midpoint frequency for channel n	Computed as $(FOBW_{low} + FOBW_{high})/2$
Highest measured Occupied Bandwidth value (OBW_{high})	Highest measured OBW value over the full environmental profile
Upper frequency edge ($FOBW_{high}$) for channel (n-1)	
Lower frequency edge ($FOBW_{low}$) for channel (n+1)	

5.3.4 Transmitter spectrum emission mask

5.3.4.1 Test conditions

- 1) The measurement shall be performed at the EUT set to the nominal operating frequency.
- 2) The measurement shall be performed with the EUT operating at its maximum operating power level.
- 3) An EUT without a permanent or temporary antenna connector shall be tested according to clause 5.3.4.2.
- 4) An EUT with a permanent or temporary antenna connector shall be tested according to clause 5.3.4.3.

5.3.4.2 Radiated measurement

A test site is selected from those described in clause B.2 based on the guidance in clause B.7.

The measurements in clause 5.3.4.4 shall be performed using corresponding radiated measurement methods described in clause B.6.

5.3.4.3 Conducted measurement

The transmitter output of the EUT shall be connected to a spectrum analyser via 20 dB attenuator.

The measurements in clause 5.3.4.4 shall be performed.

5.3.4.4 Measurement procedure

Step 1:

Determination of the offset frequency power levels.

Table 5.3.4.4-1: Parameters for Offset Frequency Power Levels

Spectrum Analyser Setting	Value
Centre frequency	Nominal operating frequency
Span	40 MHz
RBW	100 kHz
Sweep time	≥1 min
Detector Mode	RMS
Trace Mode	Max hold

- The spectrum analyser shall be configured for the parameters shown in Table 5.3.4.4-1.
- Compare the power values of the EUT with the limits defined in clause 4.3.4.3.

5.3.5 Transmitter unwanted emission in the spurious domain

5.3.5.1 Test conditions

- 1) The measurement shall be performed with the EUT set to the nominal operating frequency.
- 2) The measurement shall be performed with the EUT operating at its maximum operating power level.
- 3) The EUT shall be operated in a mode representative of normal operation.
- 4) An EUT without a permanent or temporary antenna connector shall be tested according to clause 5.3.5.2.
- 5) An EUT with a permanent or temporary antenna connector shall be tested according to clause 5.3.5.3.

5.3.5.2 Radiated measurement

A test site is selected from those described in clause B.2 based on the guidance in clause B.7.

The measurements in clause 5.3.5.4 shall be performed using corresponding radiated measurement methods described in clause B.6.

5.3.5.3 Conducted measurement

The transmitter output of the EUT shall be connected to a spectrum analyser capable of RF power measurements.

The measurements in clause 5.3.5.4 shall be performed.

5.3.5.4 Measurement procedure

5.3.5.4.1 Pre-scan

This pre-scan test procedure shall be used to identify potential unwanted emissions of the EUT.

Step 1:

- The sensitivity of the spectrum analyser should be such that the noise floor is at least 12 dB below the limits given in clause 4.3.5.3.

Step 2:

Table 5.3.5.4.1-1: Parameters for pre-scan over the range 30 MHz to 1 000 MHz

Spectrum Analyser Setting	Value
RBW	100 kHz
VBW	300 kHz
Detector Mode	Peak
Trace Mode	Max hold
	≥ 9 700
Sweep points	For spectrum analysers not supporting this number of sweep points, the frequency band may be segmented. For spectrum analysers capable of supporting twice this number of sweep points, the frequency adjustment in clause 5.3.5.4.2 (step 1, last bullet) may be omitted.
Sweep time	For non-continuous transmissions (duty cycle less than 100 %), the sweep time shall be sufficiently long, such that for each 100 kHz frequency step, the measurement time is greater than two transmissions of the EUT.

- The test equipment shall be configured for the parameters shown in Table 5.3.5.4.1-1.
- The unwanted emissions over the range 30 MHz to 1 000 MHz shall be identified.
- Allow the trace to stabilize. Any emissions identified that have a margin of less than 6 dB with respect to the limits given in clause 4.3.5.3 shall be individually measured using the procedure in clause 5.3.5.4.2 and compared to the limits given in clause 4.3.5.3.

Step 3:**Table 5.3.5.4.1-2: Parameters for pre-scan over the range 1 GHz to 6 GHz**

Spectrum Analyser Setting	Value
RBW	1 MHz
VBW	3 MHz
Detector Mode	Peak
Trace Mode	Max hold
Sweep points	<p>≥ 25 000</p> <p>For spectrum analysers not supporting this number of sweep points, the frequency band may be segmented. For spectrum analysers capable of supporting twice this number of sweep points, the frequency adjustment in clause 5.3.5.4.2 (step 1, last bullet) may be omitted.</p>
Sweep time	For non-continuous transmissions (duty cycle less than 100 %), the sweep time shall be sufficiently long, such that for each 1 MHz frequency step, the measurement time is greater than two transmissions of the EUT.

- The test equipment shall be configured for the parameters shown in Table 5.3.5.4.1-2.
- The unwanted emissions over the range 1 GHz to 6 GHz shall be identified.
- Allow the trace to stabilize. Any emissions identified that have a margin of less than 6 dB with respect to the limits given in clause 4.3.5.3 shall be individually measured using the procedure in clause 5.3.5.4.2 and compared to the limits given in clause 4.3.5.3.

5.3.5.4.2 Measurement of the emissions identified during the pre-scan

The limits for transmitter unwanted emissions in clause 4.3.5.3 refer to average power levels.

The steps below shall be used to accurately measure the individual unwanted emissions identified during the pre-scan measurements above.

For continuous transmit signals, a simple measurement using the RMS detector of the spectrum analyser is permitted. The measured values shall be recorded and compared with the limits in clause 4.3.5.3.

For non-continuous transmit signals, the measurement shall be made only over the "on" part of the burst.

Step 1:**Table 5.3.5.4.2-1: Parameters for measurement emissions identified by pre-scan**

Spectrum Analyser Setting	Value
Centre Frequency	Frequency of emission identified during pre-scan
RBW	100 kHz (F < 1 GHz) / 1 MHz (F > 1 GHz)
VBW	300 kHz (F < 1 GHz) / 3 MHz (F > 1 GHz)
Frequency span	0 Hz
Sweep mode	Single sweep
Sweep time	Suitable to capture one transmission burst. Additional measurements may be needed to identify the length of the transmission burst. In case of continuous signals, the Sweep Time shall be set to 30 ms
Sweep points	Sweep time [µs] / 1 µs with a maximum of 30 000
Trigger	Video (burst signals) or Manual (continuous signals)
Detector Mode	RMS
Trace Mode	Clear/Write

- The level of the emissions shall be measured in the time domain, using the spectrum analyser settings shown in Table 5.3.5.4.2-1.

- Adjust the centre frequency (fine tune) to capture the highest level of one burst of the emission to be measured. This fine tuning can be omitted for spectrum analysers capable of supporting twice this number of sweep points required in step 2 and step 3 from the pre-scan procedure in clause 5.3.5.4.1.

Step 2:

- Adjust the trigger level to select the transmissions with the highest power level.
- Set a window (start and stop lines) to match with the start and end of the burst and in which the RMS power shall be measured using the Time Domain Power function. If the spurious emission to be measured is a continuous signal, the measurement window shall be set to match the start and stop times of the sweep.
- Select RMS power to be measured within the selected window and note the result which is the RMS power of this particular spurious emission. Compare this value with the applicable limit provided by clause 4.3.5.3.

Repeat this procedure for every emission identified during the pre-scan. The values and corresponding frequencies shall be recorded as shown in Table 5.3.5.4.2-2.

Table 5.3.5.4.2-2: Information recorded in the test report for transmitter unwanted emissions

Parameter	Value Recorded in the Test Report
Emission Frequency	The frequency of the emission
Emission Power	The rms power value displayed by the spectrum analyser

5.3.6 Duty cycle

5.3.6.1 Test conditions

- 1) The measurement shall be performed over the frequency band defined in Table 1-1.
- 2) This test is performed using a fast power sensing equipment suitable for measurements at 800 MHz to 920 MHz. The test equipment shall be capable of not less than 1 M samples/second to provide 1 μ s resolution.
- 3) The EUT shall be configured to transmit in a manner representative of normal operation for its intended use.
- 4) An EUT without a permanent or temporary antenna connector shall be tested according to clause 5.3.6.2.
- 5) An EUT with a permanent or temporary antenna connector shall be tested according to clause 5.3.6.3.

5.3.6.2 Radiated measurement

A test site is selected from those described in clause B.2 based on the guidance in clause B.7.

The measurements in clause 5.3.6.4 shall be performed using corresponding radiated measurement methods described in clause B.6 and using the observation bandwidth and observation period specified in Table 4.3.6.3-1.

5.3.6.3 Conducted measurement

The transmitter output of the EUT shall be connected to power sensing equipment. An attenuator shall be selected in order that maximum RF power limit of the analyser is not exceeded.

The measurements in clause 5.3.6.4 shall be performed using the observation bandwidth and observation period specified in Table 4.3.6.3-1.

5.3.6.4 Measurement procedure

Table 5.3.6.4-1: Test parameters settings for duty cycle measurement

Setting	Value	Notes
Sample rate	≥ 1 M samples/second	Sampling rate for at least 1 μ s resolution
Trigger	-	Trigger setting to capture leading edge of first transmission
Frequency	Centre frequency of the frequency band as specified in Table 1-1	Centre frequency of the power measurement bandwidth
Bandwidth	Frequency band as specified in Table 1-1	Bandwidth within which power measurements are made

The power sensing equipment shall be configured for the parameters specified in Table 5.3.6.4-1.

Step 1:

The EUT shall be set to operate with a test signal representative of normal operation of the EUT for its intended purpose. The power sensing equipment shall be used to sample power in the observation bandwidth for the observation period.

The sampled power readings shall be saved.

Step 2:

The T_{On} times shall be determined using the procedures defined in clauses D.1 and D.2.

Duty cycle is the sum of the T_{On} times divided by the observation period.

The information shown in Table 5.3.6.4-2 shall be recorded in the test report.

Table 5.3.6.4-2: Information recorded in the test report for duty cycle

Parameter	Value Recorded in the Test Report
Test signal	The test signal used
Duty Cycle	The calculated value of $\sum T_{On}$ / observation period

5.3.7 Transient power

5.3.7.1 Test conditions

- 1) The measurement shall be performed on the EUT set to the nominal operating frequency.
- 2) These measurements shall be performed at the highest power level at which the transmitter is intended to operate.
- 3) An EUT without a permanent or temporary antenna connector shall be tested according to clause 5.3.7.2.
- 4) An EUT with a permanent or temporary antenna connector shall be tested according to clause 5.3.7.3.

5.3.7.2 Radiated measurement

A test site is selected from those described in clause B.2 based on the guidance in clause B.7.

The measurements in clause 5.3.7.4 shall be performed using corresponding radiated measurement methods described in clause B.6.

5.3.7.3 Conducted measurement

The transmitter output of the EUT shall be connected to a spectrum analyser. An attenuator shall be selected in order that maximum RF power limit of the analyser is not exceeded.

The measurements in clause 5.3.7.4 shall be performed.

5.3.7.4 Measurement procedure

The measurement shall be undertaken in zero span mode. The analyser's centre frequency shall be set to an offset from the operating centre frequency. These offset values and their corresponding RBW configurations are listed in Table 5.3.7.4-1.

Table 5.3.7.4-1: RBW for Transient Measurement

Measurement points: offset from centre frequency	Analyser RBW	RBW _{REF}
-0,5 x OCW - 3 kHz 0,5 x OCW + 3 kHz	1 kHz	1 kHz
±OCW	Max (RBW pattern 1, 3, 10 kHz) ≤ Offset frequency/6 (see note)	1 kHz
-0,5 x OCW - 600 kHz 0,5 x OCW + 600 kHz	100 kHz	1 kHz
0,5 x OCW - 1 200 kHz 0,5 x OCW + 1 200 kHz	300 kHz	1 kHz
NOTE: Max (RBW pattern 1, 3, 10 kHz) means the maximum bandwidth that falls into the commonly implemented 1, 3, 10 kHz RBW filter bandwidth incremental pattern of spectrum analysers.		

The used modulation shall be a test signal representative of normal operation of the EUT. The analyser shall be set to the settings of Table 5.3.7.4-2 and a measurement shall be started for each offset frequency. The EUT shall transmit at least five test signals. The peak value shall be recorded and the measurement shall be repeated at each offset frequency mentioned in Table 5.3.7.4-1.

Table 5.3.7.4-2: Parameters for Transient Measurement

Spectrum Analyser Setting	Value	Notes
VBW/RBW	10	At higher RBW values VBW may be clipped to its maximum value
Sweep time	500 ms	
RBW filter	Gaussian	
Trace Detector Function	RMS	
Trace Mode	Max hold	
Sweep points	501	
Measurement mode	Continuous sweep	
NOTE: The ratio between the number of sweep points and the sweep time shall be the same ratio as above if different number of sweep points is used.		

The recorded power values shall be converted to power values measured in RBW_{REF} by the formula in defined in clause 5.2.9.2.

The information shown in Table 5.3.7.4-3 shall be recorded in the test report for each test measurement.

Table 5.3.7.4-3: Information recorded in the test report for transmitter transient power

Value	Notes
Operating frequency	The highest or lowest operating frequency and any other frequencies used in the test case
Peak measured power	The peak power value displayed by the spectrum analyser
Peak power	Calculated peak power in RBW _{REF}

5.4 Conformance test suites for receivers

5.4.1 Receiver sensitivity

5.4.1.1 Test Conditions

- 1) The measurements shall be performed on the EUT set to the nominal operating frequency.
- 2) If possible, the EUT shall be operated with any FEC or automatic retransmission facility disabled.
- 3) An EUT without a permanent or temporary antenna connector shall be tested according to clause 5.4.1.2.
- 4) An EUT with a permanent or temporary antenna connector shall be tested according to clause 5.4.1.3.

5.4.1.2 Radiated measurement

A test site is selected from those described in clause B.2 based on the guidance in clause B.7.

The output of the signal generator shall be connected to a transmit test antenna with the same antenna polarization as the EUT. The transmit test antenna shall be placed in the test site.

The EUT shall be placed at the location of the turntable at the orientation of the most sensitive position.

The measurement in clause 5.4.1.4 shall be performed using appropriate radiated measurement methods described in clause B.6.5.

5.4.1.3 Conducted measurement

The EUT shall be connected to the output of a signal generator.

The measurements in clause 5.4.1.4 shall be performed.

5.4.1.4 Measurement procedure

The signal generator, modulated with an appropriate test signal, shall be set to nominal operating frequency.

Step 1:

The operation of the EUT shall be started as a receiver on the nominal operating frequency.

Step 2:

The level of the input signal to the EUT shall be adjusted until the wanted criterion as described in clause 4.4.1.3 is just exceeded.

Step 3:

With the signal generator settings unchanged, the power received by EUT shall be established by appropriate means.

The receiver sensitivity shall be noted.

Step 4:

Steps 1 to 3 shall be repeated for each data rate at which the EUT is able to operate.

Step 5:

The information shown in Table 5.4.1.4-1 shall be recorded in the test report.

Table 5.4.1.4-1: Information Recorded in the Test Report

Value	Notes
Test signal	The test signal used
Data rate	EUT data rate
FEC or ARQ state	FEC/ARQ enabled or disabled
Measurement method	BER/message success ratio/other
Measurement description	Description of message success ratio calculation/other measurement method if applicable
Nominal operating frequency	
Receiver sensitivity	Measured signal generator power level

5.4.2 Adjacent channel selectivity

5.4.2.1 Test conditions

- 1) The measurement is performed on the EUT set to the nominal operating frequency.
- 2) An EUT without a permanent or temporary antenna connector shall be tested according to clause 5.4.2.2.
- 3) An EUT with a permanent or temporary antenna connector shall be tested according to clause 5.4.2.3.

5.4.2.2 Radiated measurement

A test site is selected from those described in clause B.2 based on the guidance in clause B.7.

Signal generators A and B together with the combiner, shown in Figure 5.4.2.3-1, shall be placed outside the test site.

The output of the combiner shall be connected to a transmit test antenna with the same antenna polarization as the EUT. The transmit test antenna shall be placed in the test site.

The EUT shall be placed at the location of the turntable at the orientation of the most sensitive position.

The measurements in clause 5.4.2.4 shall be performed using appropriate radiated measurement methods described in clause B.6.5.

5.4.2.3 Conducted measurement

Two signal generators A and B shall be connected to the EUT via a combining network as shown in Figure 5.4.2.3-1.

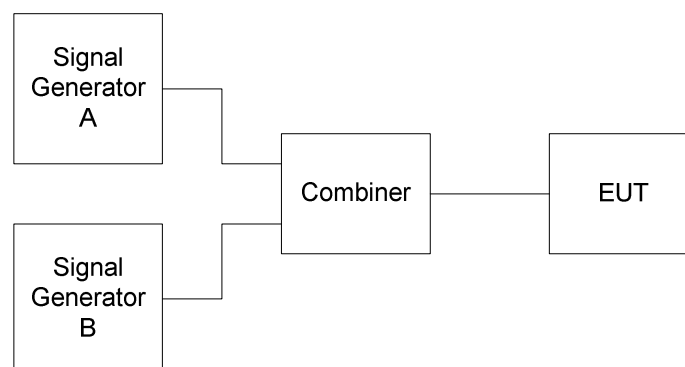
**Figure 5.4.2.3-1: Measurement arrangement**

The measurements in clause 5.4.2.4 shall be performed.

5.4.2.4 Measurement procedure

Signal generator A shall be configured to generate the wanted signal at the nominal operating frequency of the EUT receiver.

Signal generator B shall be configured to generate the same type of signal as the wanted signal and shall be adjusted to the Adjacent Channel centre frequency immediately above the operating channel.

Signal generator B shall be powered off.

Signal generator A shall be set to the minimum level which gives the wanted performance criterion of the EUT or the reference level in Table 4.4.1.3-1, whichever is the higher. The output level of generator A shall then be increased by 3 dB. Signal generator B is then switched on and the signal amplitude is adjusted to the minimum level at which the wanted performance criterion is just not achieved.

The ACS is then the power received from generator B at the EUT antenna connector.

This can either be measured on the antenna connector in case of conducted tests or be calculated for radiated test (e.g. $ACS = Tx \text{ power generator B} - \text{combiner loss} + \text{antenna gain test antenna} + \text{appropriate antenna gain EUT} - \text{path loss}$) (see clause B.6.5).

The measurements shall be repeated with signal generator B adjusted to the Adjacent Channel centre frequency immediately below the Operating Channel.

The information shown in Table 5.4.2.4-1 shall be recorded in the test report for each measured Adjacent Channel.

Table 5.4.2.4-1: Information Recorded in the Test Report

Value	Notes
EUT frequency	Nominal Operating Frequency of the receiver
Upper Adjacent Channel Selectivity at Nominal operating Frequency plus OCW	
Lower Adjacent Channel Selectivity at Nominal Operating Frequency minus OCW	

5.4.3 Receiver spurious response rejection

5.4.3.1 Test conditions

- 1) The measurements shall be performed on the EUT set to the nominal operating frequency.
- 2) An EUT without a permanent or temporary antenna connector shall be tested according to clause 5.4.3.2.
- 3) An EUT with a permanent or temporary antenna connector shall be tested according to clause 5.4.3.3.

5.4.3.2 Radiated measurement

A test site is selected from those described in clause B.2 based on the guidance in clause B.7.

Signal generators A and B together with the combiner, shown in Figure 5.4.2.3-1, shall be placed outside the test site.

The output of the combiner shall be connected to a transmit test antenna with the same antenna polarization as the EUT. The transmit test antenna shall be placed in the test site.

The EUT shall be placed at the location of the turntable at the orientation of the most sensitive position.

The measurements in clause 5.4.3.4 shall be performed.

5.4.3.3 Conducted measurement

Two signal generators A and B shall be connected to the EUT via a combining network as shown in Figure 5.4.2.3-1.

The measurements in clause 5.4.3.4 shall be performed.

5.4.3.4 Measurement procedure

To determine the frequencies at which spurious responses can occur the following calculations shall be made:

- Calculation of the "limited frequency range":
 - a) The limited frequency range is defined as the frequency of the local oscillator signal (f_{LO}) applied to the first mixer of the receiver plus or minus the Intermediate Frequency (IF) ($f_{LO} \pm f_{IF}$) or where more than 1 IF is involved, at the image frequency of the first and subsequent frequency conversions ($f_{LO} \pm f_{IF1}$) and ($f_{LO} \pm f_{IF2}$).
 - b) At frequency separation corresponding to half of the first IF from the nominal operating frequency (f_{nom}): $f_{nom} \pm (f_{IF1}/2)$.

For the calculations a) and b) above, the frequency of the receiver, the frequency of the local oscillator signal (f_{LO}) applied to the 1st mixer of the receiver, the intermediate frequencies (f_{i1} , f_{i2} , etc.) are EUT properties (Annex F).

Signal generator A shall be configured to generate the wanted signal at the operating frequency of the EUT receiver.

Signal generator B shall be unmodulated and shall be adjusted to the test frequency as determined above.

Step 1:

Signal generator B shall be switched off. Signal generator A shall be set to the minimum level which gives the wanted performance criterion of EUT or the reference level in Table 4.4.1.3-1, whichever is the higher. The output level of generator A shall then be increased by 3 dB.

Step 2:

Signal generator B is then switched on and the signal amplitude is adjusted to the minimum level at which the wanted performance criterion is just not achieved.

With signal generator B settings unchanged, the receiver shall be replaced with a RF power measuring equipment. The power into the measuring equipment shall be measured and noted.

The spurious response rejection is then the conducted power received from generator B at the EUT antenna connector.

This can either be measured on the antenna connector for conducted test or be calculated for radiated test (see clause B.6.5).

Spurious response rejection values shall not be less the requested technical requirement.

The information shown in Table 5.4.3.4-1 shall be recorded in the test report for each measurement.

Table 5.4.3.4-1: Information Recorded in the Test Report

Value	Notes
Operating Frequency	Nominal centre frequency of the receiver
Signal generator A	Power level of signal generator A
Spurious response rejection	Power level of signal generator B
NOTE: If several Operational Frequency bands are used by the equipment, measurement have to be performed in each band.	

5.4.4 Blocking

5.4.4.1 Test conditions

- 1) The measurement is performed at the EUT operating frequency.
- 2) An EUT without a permanent or temporary antenna connector shall be tested according to clause 5.4.4.2.
- 3) An EUT with a permanent or temporary antenna connector shall be tested according to clause 5.4.4.3.

5.4.4.2 Radiated measurement

A test site is selected from those described in clause B.2 based on the guidance in clause B.7.

Signal generators A and B together with the combiner, shown in Figure 5.4.2.3-1, shall be placed outside the test site.

The output of the combiner shall be connected to a transmit test antenna with the same antenna polarization as the EUT. The transmit test antenna shall be placed in the test site.

The EUT shall be placed at the location of the turntable at the orientation of the most sensitive position.

The measurements in clause 5.4.4.4. shall be performed using appropriate radiated measurement methods described in clause B.6.5.

5.4.4.3 Conducted measurement

Two signal generators A and B shall be connected to the EUT via a combining network as shown in Figure 5.4.2.3-1.

The measurements in clause 5.4.4.4 shall be performed.

5.4.4.4 Measurement procedure

Signal generator A shall be set to an appropriate modulated test signal at the operating frequency of the EUT receiver.

Signal generator B shall be unmodulated.

Measurements shall be carried out at frequencies of the unwanted signal at ± 2 MHz and ± 10 MHz offset from nominal operating frequency.

Step 1:

Signal generator B shall be powered off. Signal generator A shall be set to the minimum level which gives the wanted performance criterion of EUT or the reference level in Table 4.4.1.3-1, whichever is the higher. The output level of generator A shall then be increased by 3 dB unless otherwise specified in technical requirement.

Step 2:

Signal generator B is powered on and set to operate at the nominal operating frequency - offset frequency.

Signal generator B is then switched on and the signal amplitude is adjusted to the minimum level at which the wanted performance criterion is not achieved.

With signal generator B settings unchanged, the receiver shall be replaced with a RF power measuring equipment. The power into the measuring equipment shall be measured and noted.

The blocking level is then the conducted power received from generator B at the EUT antenna connector.

This can either be measured on the antenna connector for conducted test or be calculated for radiated test (see clause B.6.5).

The blocking level shall be higher or equal to the blocking power level requested in the technical requirement clause.

Step 3:

The measurement in steps 1 to 3 shall be repeated with signal offsets at required frequencies.

Step 4:

The information shown in Table 5.4.4.4-1 shall be recorded in the test report for each measured signal level and unwanted signal offset.

Table 5.4.4.4-1: Information Recorded in the Test Report

Value	Notes
Nominal operating frequency	
Signal generator A	Power level of signal generator A
Blocking level	Power level of signal generator B

5.4.5 Receiver spurious emission

5.4.5.1 Test conditions

- 1) The measurements shall be performed under the EUT set to the nominal operating frequency.
- 2) Radiated measurements shall be performed on a test site selected from clause B.2 based on the guidance in clause B.7, with corresponding measurement procedures, which fulfils the measurement requirements for the specified frequency range.
- 3) An EUT without a permanent or temporary antenna connector shall be tested according to clause 5.4.5.2.
- 4) An EUT with a permanent or temporary antenna connector shall be tested according to clause 5.4.5.3.

5.4.5.2 Radiated measurement

The EUT shall be placed in a test site selected from those described in clause B.2 based on the guidance in clause B.7 using a measurement antenna of length chosen to correspond to the frequency of the measuring receiver.

The EUT shall be connected to its normal operating antenna.

The output of the measurement antenna shall be connected to the measuring receiver.

The measurements described in clause 5.4.5.4.2 shall be performed using radiated measurement methods described in clause B.6 corresponding to the selected test site.

5.4.5.3 Conducted measurement

The EUT shall be connected to an artificial antenna which shall be connected to the test equipment.

The measurements described in clause 5.4.5.4.1 shall be performed.

5.4.5.4 Measurement procedure

5.4.5.4.1 Conducted measurement

Step 1:

The operation of the EUT as a receiver shall be started.

The measuring receiver shall be tuned over the frequency range shown in Table 5.4.5.4.1-1.

Table 5.4.5.4.1-1: Receiver spurious emissions measurement frequency range - conducted

Frequency range
9 kHz to 6 GHz
NOTE: The measurements need only to be performed over the frequency range 4 GHz to 6 GHz if emissions are detected within 10 dB of the of the specified limit between 1,5 GHz and 4 GHz.

Step 2:

At each frequency at which a spurious emission is detected, the power level shall be measured and noted.

The information shown in Table 5.4.5.4.1-2 shall be recorded in the test report for each spurious emission.

Table 5.4.5.4.1-2: Information recorded in the test report for receiver spurious emissions

Value	Notes
Frequency	Frequency of spurious emission
Power level	Measured power level of spurious emission
NOTE: The power level is the spurious level delivered into the artificial antenna load.	

5.4.5.4.2 Radiated measurement

Step 1:

The operation of the EUT as a receiver shall be started.

The measuring receiver shall be tuned over the frequency range shown in Table 5.4.5.4.2-1.

Table 5.4.5.4.2-1: Receiver spurious emissions measurement frequency range - radiated

Frequency range
30 MHz - 6 GHz
NOTE: The measurements need only to be performed over the frequency range 4 GHz to 6 GHz if emissions are detected within 10 dB of the specified limit between 1,5 GHz and 4 GHz.

Step 2:

For each frequency at which a spurious emission is detected the measurement procedure for the selected test site as described in clause B.6 shall be performed.

The maximum signal level detected by the measuring receiver for vertical and horizontal polarization shall be noted.

Step 3:

The substitution measurement defined in clause B.6.4 shall be performed with the frequency of the calibrated signal generator set to the frequency of the spurious emission detected and, if necessary, the input attenuator setting of the measuring receiver adjusted in order to increase the sensitivity of the measuring receiver.

The radiated power for vertical and horizontal polarization, corrected for any change of input attenuator setting of the measuring receiver, shall be noted.

The measure of the effective radiated power of the spurious emission is the larger of the two power levels at the input to the substitution antenna.

The information shown in Table 5.4.5.4.2-1 shall be recorded in the test report for each spurious emission.

5.4.6 Receiver maximum input signal level

5.4.6.1 Test conditions

- 1) The measurements shall be performed on the EUT set to the nominal operating frequency.
- 2) The measurement shall be performed for each data rate at which the EUT is able to operate.
- 3) An EUT without a permanent or temporary antenna connector shall be tested according to clause 5.4.6.2.
- 4) An EUT with a permanent or temporary antenna connector shall be tested according to clause 5.4.6.3.

5.4.6.2 Radiated measurement

A test site is selected from those described in clause B.2 based on the guidance in clause B.7.

The output of the signal generator shall be connected to a transmit test antenna with the same antenna polarization as the EUT. The transmit test antenna shall be placed in the test site.

The EUT shall be placed at the location of the turntable at the orientation of the most sensitive position.

The measurement in clause 5.4.6.4 shall be performed using appropriate radiated measurement methods described in clause B.6.5.

5.4.6.3 Conducted measurement

The EUT shall be connected to the output of a signal generator.

The measurements in clause 5.4.6.4 shall be performed.

5.4.6.4 Measurement procedure

Step 1:

The signal generator, modulated with a permitted test signal from Table 5.2.8-1, shall be set to nominal operating frequency. The operation of the EUT shall be started as a receiver on the same nominal operating frequency.

Step 2:

The level of the input signal to the EUT shall be increased until the wanted criteria (see clause 4.2) is no longer obtained or the limit specified in Table 4.4.6.3-1 is reached.

Step 3:

With the signal generator settings unchanged, the output of the signal generator shall be connected to an RF power measuring equipment.

For a conducted test:

- The power into the measuring equipment shall be measured.

For a radiated test:

- The power into the measuring equipment plus the gain of the test antenna minus cables losses shall be measured.

The receive power level shall be noted.

Step 4:

The information shown in Table 5.4.6.4-1 shall be recorded in the test report.

Table 5.4.6.4-1: Information Recorded in the Test Report

Value	Notes
Test signal	The test signal used
Data rate	EUT data rate
FEC or ARQ state	FEC/ARQ enabled or disabled
Measurement method	BER/message success ratio/other
Measurement description	Description of message success ratio calculation/other measurement method if applicable
Nominal operating frequency	
Maximum input signal level	Measured power level

Step 5:

Steps 1 to 4 shall be repeated for each data rate at which the EUT is able to operate.

5.5 Conformance test suites for spectrum access

5.5.1 Clear channel assessment threshold

5.5.1.1 Test conditions

- 1) The measurements shall be performed on the EUT set to the nominal operation frequency.
- 2) An equipment (EUT) without a permanent or temporary antenna connector shall be tested according to clause 5.5.1.2.
- 3) An equipment (EUT) with a permanent or temporary antenna connector shall be tested according to clause 5.5.1.3.

5.5.1.2 Radiated measurement

A test site is selected from those described in clause B.2 based on the guidance in clause B.7.

The signal generator together with the combiner and spectrum analyser, as shown in Figure 5.5.1.2-1, shall be placed outside the test site.

The output of the combiner shall be connected to a transmit test antenna with the same antenna polarization as the EUT. The transmit test antenna shall be placed in the test site.

The EUT shall be placed at the location of the turntable at the orientation of the most sensitive position.

The measurement in clause 5.5.1.4 shall be performed using radiated measurement methods described in clause B.6.5 corresponding to the selected test site.

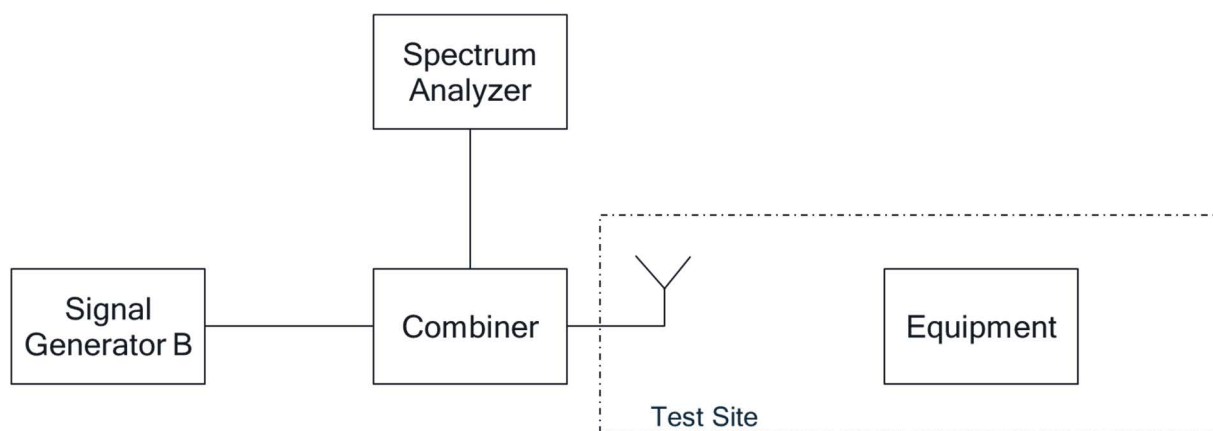

Figure 5.5.1.2-1: Radiated clear channel assessment threshold measurement arrangement

5.5.1.3 Conducted measurement

A signal generator and a spectrum analyser shall be connected to the EUT antenna connector via a combining network as shown in Figure 5.5.1.3-1.

The measurements in clause 5.5.1.4 shall be performed.

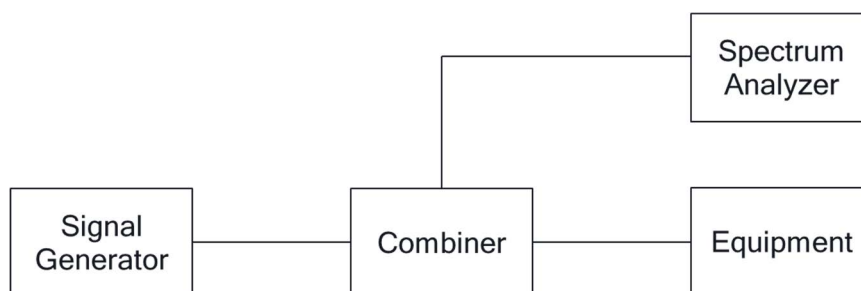

Figure 5.5.1.3-1: Conducted clear channel assessment threshold measurement arrangement

5.5.1.4 Measurement procedure

Table 5.5.1.4-1: Test parameters settings for CCA threshold measurement

Setting	Value
Centre frequency	The nominal EUT operating frequency
RBW	1 % to 3 % of OCW without being below 100 Hz
VBW	3 x RBW
Span	At least 2 x Operating Channel width
Detector Mode	RMS
Trace Mode	Max. Hold

The spectrum analyser shall be configured for the parameters specified in Table 5.5.1.4-1.

Step 1:

Operation of the EUT as a receiver shall be started with its CCA function active.

The signal generator, modulated with a permitted test signal, shall be adjusted to the nominal operating frequency.

The spectrum analyser levels shall be adjusted to provide display of the signal of the signal generator.

Step 2:

The output power level of the signal generator shall be set to 20 dB above the receiver sensitivity limit given in Table 4.4.1.3-1.

The EUT shall be instructed to transmit.

NOTE 1: The means of instructing the EUT to transmit is outside the scope of the present document.

The presence of any signal from the EUT detected by the spectrum analyser shall be noted.

NOTE 2: Allowance should be made for any EUT specific protocol delays associated with CCA operation before determining whether the EUT emits a signal or not.

Step 3:

The level of the signal generator shall be reduced in steps of 1 dB until the equipment starts to transmit.

NOTE 3: There may be EUT specific protocol delays associated with collision avoidance operation before the EUT begins to transmit once the CCA threshold has been reached. Any such delays should be taken into account in the rate at which the signal generator level is reduced.

Step 4:

With the signal generator settings unchanged, the output of the signal generator shall be connected to an RF power measuring equipment.

The power into the measuring equipment shall be measured and noted.

For a conducted test:

- The power into the measuring equipment shall be measured.

For a radiated test:

- The power into the measuring equipment plus the gain of the test antenna minus cables losses shall be measured.

The measured RF power level is the CCA threshold and shall be noted.

The CCA threshold being recorded shall meet the limit in Table 4.5.1.3-1.

The information shown in Table 5.5.1.4-2 shall be recorded in the test report.

Table 5.5.1.4-2: Information recorded in the test report for CCA threshold

Value	Notes
Test signal	The test signal used
CCA threshold	Recorded CCA threshold
Presence of unexpected EUT signal	Any transmission detected at the spectrum analyser in step 2
NOTE: The presence of unexpected EUT transmission is a test failure.	

5.5.2 Listen before talk

5.5.2.1 Test conditions

- 1) The measurements shall be performed on the EUT set to the nominal frequency.
- 2) This test is performed using a fast power sensing equipment for measurements at 800 MHz to 920 MHz and a protocol analyser. The test equipment shall be capable of not less than 1 M samples/second to provide 1 μ s resolution. The protocol analyser shall be able to receive, interpret and timestamp transmissions from the EUT and companion device.
- 3) The EUT and a companion device able to respond to EUT transmissions with acknowledgements or dialog exchanges shall be configured to transmit in a manner representative of normal operation for its intended use.

NOTE: Attenuators adequate to protect receivers from excess signal power are assumed.

- 4) An EUT without a permanent or temporary antenna connector shall be tested according to clause 5.5.2.2.
- 5) An EUT with a permanent or temporary antenna connector shall be tested according to clause 5.5.2.3.

5.5.2.2 Radiated measurement

A test site is selected from those described in clause B.2 based on the guidance in clause B.7.

All measurements in the test case shall be performed using radiated measurement methods described in clause B.6.5 corresponding to the selected test site.

5.5.2.3 Conducted measurement

A signal generator and a spectrum analyser shall be connected to the EUT antenna connector via a combining network as shown in Figure 5.5.1.3-1.

All measurements in the test case shall be performed directly with the measuring equipment.

5.5.2.4 Measurement procedure

The power sensing equipment shall be configured for the parameters specified in Table 5.5.2.4-1.

Table 5.5.2.4-1: Test parameters settings for listen before talk measurement

Setting	Value	Notes
Sample rate	≥ 1 M samples/second	Sampling rate for at least 1 μ s resolution
Trigger	-	Trigger setting to capture leading edge of first transmission
Frequency	Nominal operating frequency	Centre frequency of the power measurement bandwidth
Bandwidth	Occupied bandwidth	Bandwidth within which power measurements are made
NOTE: The trigger setting is determined by the test laboratory.		

Step 1:

The signal generator, modulated with a permitted test signal, shall be adjusted to the nominal operating frequency.

The EUT shall be set to operate with a permitted test signal from Table 5.2.8-1.

Step 2:

The output power level of the signal generator shall be set to 10 dB above the CCA threshold as determined in clause 5.5.1.

The power meter shall be started.

The EUT shall be instructed to transmit.

NOTE 1: The means of instructing the EUT to transmit is outside the scope of the present document.

Step 3:

The level of the signal generator shall be reduced to 10 dB below the CCA threshold.

Step 4:

The power meter shall be stopped when the EUT transmits any signal in the operating frequency channel.

The power samples shall be saved.

Step 5:

The time between the signal generator level falling to 10 dB below the CCA threshold and the start of the transmission from the EUT shall be calculated from the saved power meter samples and saved as a transmission delay sample.

Step 6:

Steps 2 to 5 shall be repeated not less than 20 times.

Step 7:

The transmission delay samples, in the order obtained, shall be used as input values to runstest.

NOTE 2: Most statistical software libraries or packages provide a runstest function e.g. Matlab function `[h, p, stats] = runstest(x, median(x))`, where `x` is the input sample vector, `h` is the result of the null hypothesis, `p` is the probability that the samples are random and `stats` is an array providing counts of the runs and the test statistic value.

Step 8:

Replace the signal generator by a companion device. The companion device shall be set to operate with a permitted test signal from Table 5.2.8-1.

The protocol analyser capture shall be started.

Step 9:

The companion device shall be instructed to transmit a message to the EUT that solicits a short response message.

NOTE 3: The means of instructing the companion device to transmit is outside the scope of the present document.

Step 10:

On completion of the communications exchange between the EUT and companion device, the protocol analyser shall be stopped and the captured transmissions saved.

NOTE 4: The means of determining the completion of the exchange is outside the scope of the present document.

Step 11:

Steps 10 to 11 shall be repeated not less than 20 times.

Step 12:

Each T_{MRI} , shall be derived from the saved protocol analyser transmission timestamps and saved.

Each T_{MRD} shall be derived from the saved protocol analyser transmission timestamps and saved.

The information shown in Table 5.5.2.4-2 shall be recorded in the test report.

Table 5.5.2.4-2: Information recorded in the test report for LBT

Value	Notes
Test signal	The test signal used
Minimum CCA interval	The shortest measured transmit delay
Largest value of T_{MRI}	Longest maximum response interval
Largest value of T_{MRD}	Longest maximum response duration
Null hypothesis result	Not rejected: the test statistic < 1,96 or Rejected: the test statistic \geq 1,96
Number of runs	The number of runs
Number of values above median	The number of values above median
Number of values below median	The number of values below median

5.6 Conformance test suites for functional requirements

5.6.1 Master Network Access Point

5.6.1.1 Test conditions

- 1) The measurements shall be performed on the EUT set to the nominal operation frequency.
- 2) This test is performed using a fast power sensing equipment for measurements at 800 MHz to 920 MHz. The test equipment shall be capable of not less than 100 K samples/second to provide 10 μ s resolution.
- 3) The EUT shall be configured to operate in a manner representative of normal operation for its intended use.
- 4) An EUT without a permanent or temporary antenna connector shall be tested according to clause 5.6.1.2.
- 5) An EUT with a permanent or temporary antenna connector shall be tested according to clause 5.6.1.3.

5.6.1.2 Radiated measurement

A test site is selected from those described in clause B.2 based on the guidance in clause B.7.

All measurements in the test case shall be performed using radiated measurement methods described in clause B.6.5 corresponding to the selected test site.

5.6.1.3 Conducted measurement

A signal generator and a spectrum analyser shall be connected to the EUT antenna connector via a combining network as shown in Figure 5.5.1.3-1.

All measurements in the test case shall be performed directly with the measuring equipment.

5.6.1.4 Measurement procedure

Table 5.6.1.4-1: Test parameters settings

Setting	Value	Notes
Sample rate	≥ 100 K samples/second	Sampling rate for at least 10 μ s resolution
Trigger	-	Trigger setting to capture leading edge of first transmission
Frequency	Nominal operating frequency	
Observation period	> 900 seconds	Observation time to sample power in the observation bandwidth.
NOTE: The trigger setting is determined by the test laboratory.		

The power sensing equipment shall be configured for the parameters specified in Table 5.6.1.4-1.

Step 1:

The EUT shall be set to operate with a signal representative of normal operation of the EUT for its intended purpose. The power sensing equipment shall be used to sample power in the observation bandwidth for the observation period.

Step 2:

The presence of any signal from the EUT detected by the spectrum analyser shall be noted.

Step 3:

The periodicity, which is the time between the start of two consecutive signals from the EUT detected by the spectrum analyser shall be noted. The periodicity shall meet the requirement in clause 4.6.1.

The information shown in Table 5.3.6.4-2 shall be recorded in the test report.

Table 5.6.1.4-2: Information recorded in the test report for network access point

Parameter	Value Recorded in the Test Report
Signal	The signal used.
Periodicity	The time between the start of two consecutive signals.

5.6.2 Network Access Point (NAP)

5.6.2.1 Test conditions

- 1) The measurements shall be performed on the EUT set to the nominal frequency.
- 2) This test is performed with:
 - a) Analyser A - a protocol analyser able to receive and interpret radio transmissions between the EUT and nodes in the data network.
 - b) Analyser B - a protocol analyser able to receive and interpret transmissions between the EUT and the external network or service.
- 3) The EUT shall be configured to operate in a manner representative of normal operation for its intended use.

5.6.2.2 Measurement Procedure

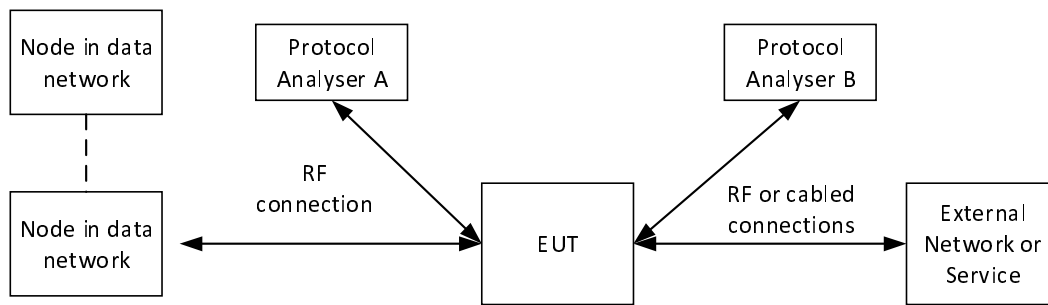

Figure 5.6.2.2-1: Network access point analyser arrangement

Step 1:

- If necessary, the EUT shall be connected to analyser B.
- Analyser A and analyser B shall be set to record all traffic.

Table 5.6.2.2-1: Test parameters settings for NAP observations

Setting	Value	Notes
Background observation period	3 600 seconds	Period to capture background traffic from data network and external network or service
NAP response period	< NAP message transit delay	Period to capture NAP response to requests (see note)
NOTE: The test may be shortened if the NAP response is smaller than the limit defined in clause 4.6.2.3.		

- The EUT and all necessary companion equipment shall be set to operate in a normal manner for their intended use with a permitted test signal (see Table 5.2.8-1). traffic shall be recorded by both analysers over the background observation period defined in Table 5.6.2.2-1.
- The captured traffic shall be saved and traffic capture on the two analysers restarted.

Step 2:

- A request to transfer information from a node within the data network to the external network or service shall be generated.

NOTE 1: The means to generate such information is outside the scope of the present document.

- The traffic recorded by both analysers over the NAP response period defined in Table 5.6.2.2-1 shall be saved and traffic capture on the two analysers restarted.

Step 3:

- A request to transfer information from the external network or service to a node within the data network shall be generated.

NOTE 2: The means to generate such information is outside the scope of the present document.

- The traffic recorded by both analysers over the NAP response period defined in Table 5.6.2.2-1 shall be saved.

Step 4:

- Ignoring equivalent traffic to that recorded in step 1:
 - The saved traffic from step 2 shall be analysed to identify the generated request and any following response by the EUT on the link to the external network or service.

- The saved traffic from step 3 is analysed to identify the generated request and any following response by the EUT into the data network.

The information in Table 5.6.2.2-2 is recorded in the test report.

Table 5.6.2.2-2: Information recorded in the test report for NAP

Parameter	Value recorded in the test report
NAP response to data network request	Whether the NAP responded to a request from within the data network to the external network or service
NAP response to external network or service request	Whether the NAP responded to a request from the external network or service to the data network

The pass criterion is that at least one NAP response shall be observed.

Annex A (informative): Relationship between the present document and the essential requirements of Directive 2014/53/EU

The present document has been prepared under the Commission's standardisation request C(2015) 5376 final [i.3] to provide one voluntary means of conforming to the essential requirements of Directive 2014/53/EU [i.1] on the harmonisation of the laws of the Member States relating to the making available on the market of radio equipment and repealing Directive 1999/5/EC.

Once the present document is cited in the Official Journal of the European Union under that Directive, compliance with the normative clauses of the present document given in Table A-1 confers, within the limits of the scope of the present document, a presumption of conformity with the corresponding essential requirements of that Directive, and associated EFTA regulations.

Table A-1: Relationship between the present document equipment and the essential requirements of Directive 2014/53/EU

Harmonised Standard ETSI EN 304 220-1					
Requirement				Requirement Conditionality	
No	Description	Essential requirements of Directive	Clause(s) of the present document	U/C	Condition
1	Frequency error	3.2	4.3.1	U	
2	Effective radiated power	3.2	4.3.2	U	
3	Occupied bandwidth	3.2	4.3.3	U	
4	Transmitter spectrum emission mask	3.2	4.3.4	U	
5	Transmitter unwanted emissions in the spurious domain	3.2	4.3.5	U	
6	Duty cycle	3.2	4.3.6	U	
7	Listen before talk	3.2	4.5.2	U	
8	Receiver sensitivity	3.2	4.4.1	U	
9	Adjacent channel selectivity	3.2	4.4.2	U	
10	Receiver spurious response rejection	3.2	4.4.3	U	
11	Blocking	3.2	4.4.4	U	
12	Receiver spurious emission	3.2	4.4.5	U	
13	Receiver maximum input signal level	3.2	4.4.6	U	
14	Master Network Access Point	3.2	4.6.1	C	Applies only to Type 2 equipment
15	Network Access Point (NAP)	3.2	4.6.2	U	

Key to columns:

Requirement:

No A unique identifier for one row of the table which may be used to identify a requirement.

Description A textual reference to the requirement.

Essential requirements of Directive

Identification of article(s) defining the requirement in the Directive.

Clause(s) of the present document

Identification of clause(s) defining the requirement in the present document unless another document is referenced explicitly.

Requirement Conditionality:

U/C	Indicates whether the requirement is unconditionally applicable (U) or is conditional upon the manufacturer's claimed functionality of the equipment (C).
Condition	Explains the conditions when the requirement is or is not applicable for a requirement which is classified "conditional".

Presumption of conformity stays valid only as long as a reference to the present document is maintained in the list published in the Official Journal of the European Union. Users of the present document should consult frequently the latest list published in the Official Journal of the European Union.

Other Union legislation may be applicable to the product(s) falling within the scope of the present document.

Annex B (normative): Test sites and arrangements for radiated measurement

B.1 General considerations

This annex introduces three most commonly available test sites and a test fixture, to be used in the radiated measurements in accordance with the present document.

Subsequently the following items will be described:

- Open Area Test Site (OATS).
- Semi Anechoic Room (SAR).
- Fully Anechoic Room (FAR).
- Test fixture for relative measurements.

The first three are generally referred to as free field test sites. Both absolute and relative measurements can be performed on these sites. They will be described in clause B.2. Clause B.3 describes the antennas used in these test sites. The test fixture can only be used for relative measurements, and will be described in Annex E.

Where absolute measurements are to be carried out, the chamber should be verified. A detailed verification procedure is described in clause 6 of ETSI TR 102 273-4 [i.13] for the OATS, in clause 6 of ETSI TR 102 273-3 [i.14] for the SAR, and in clause 6 of ETSI TR 102 273-2 [i.15] for the FAR.

Information for calculating the measurement uncertainty of measurements on one of these test sites can be found in ETSI TR 100 028 parts 1 and 2 [i.11], ETSI TR 102 273-2 [i.15], ETSI TR 102 273-3 [i.14] and ETSI TR 102 273-4 [i.13].

B.2 Radiation test sites

B.2.1 Open Area Test Site (OATS)

An Open Area Test Site comprises a turntable at one end and an antenna mast of variable height at the other end above a ground plane which, in the ideal case, is perfectly conducting and of infinite extent. In practice, while good conductivity can be achieved, the ground plane size has to be limited. A typical Open Area Test Site is shown in Figure B.2.1-1.

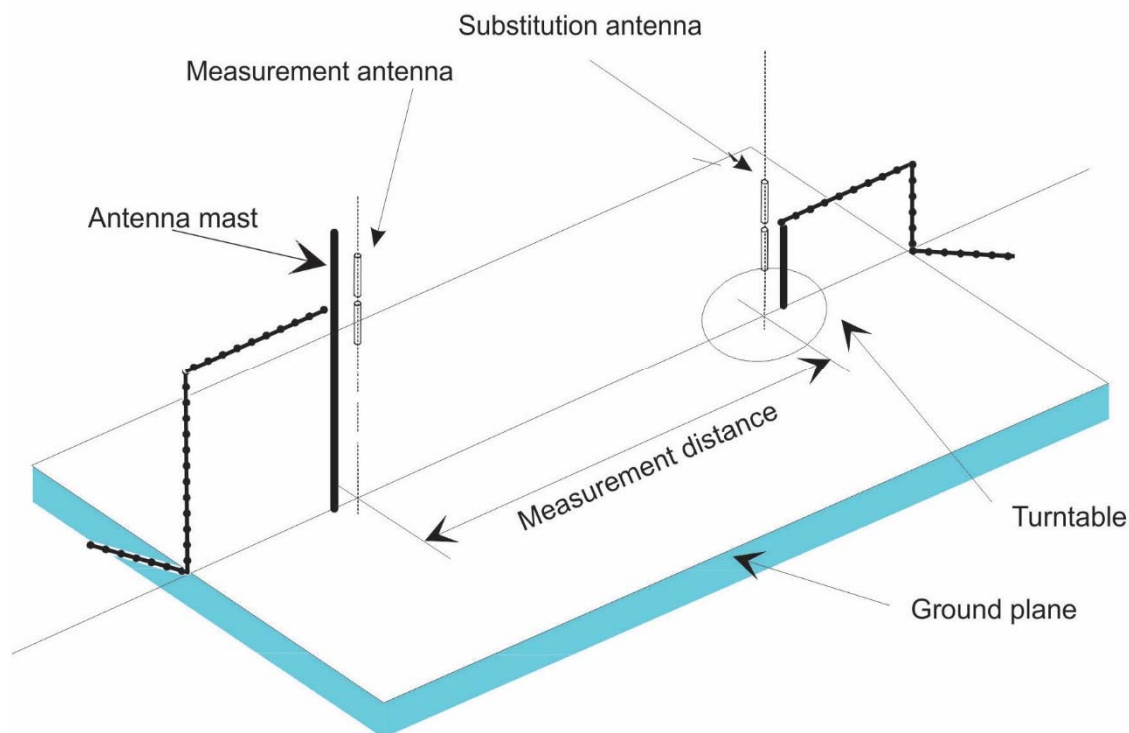

Figure B.2.1-1: A typical Open Area Test Site

The ground plane creates a wanted reflection path, such that the signal received by the receiving antenna is the sum of the signals received from the direct and reflected transmission paths. The phasing of these two signals creates a unique received level for each height of the transmitting antenna (or EUT) and the receiving antenna above the ground plane.

The antenna mast provides a variable height facility (from 1 m to 4 m) so that the position of the measurement antenna can be optimized for maximum coupled signal between antennas or between a EUT and the measurement antenna.

A turntable is capable of rotation through 360° in the horizontal plane and it is used to support the test sample (EUT) at a specified height, 1,5 m above the ground plane.

The measurement distance and minimum chamber dimensions can be found in clause B.2.4. The distance used in actual measurements shall be recorded with the test results.

Further information on Open Area Test Sites can be found in ETSI TR 102 273-4 [i.13].

B.2.2 Semi Anechoic Room

A Semi Anechoic Room is - or anechoic chamber with a conductive ground plane - is an enclosure, shielded, whose internal walls and ceiling are covered with radio absorbing material. The floor, which is metallic, is not covered by absorbing material and forms the ground plane. The chamber usually contains an antenna mast at one end and a turntable at the other end. A typical anechoic chamber with a conductive ground plane is shown in Figure B.2.2-1.

This type of test chamber attempts to simulate an ideal Open Area Test Site, whose primary characteristic is a perfectly conducting ground plane of infinite extent.

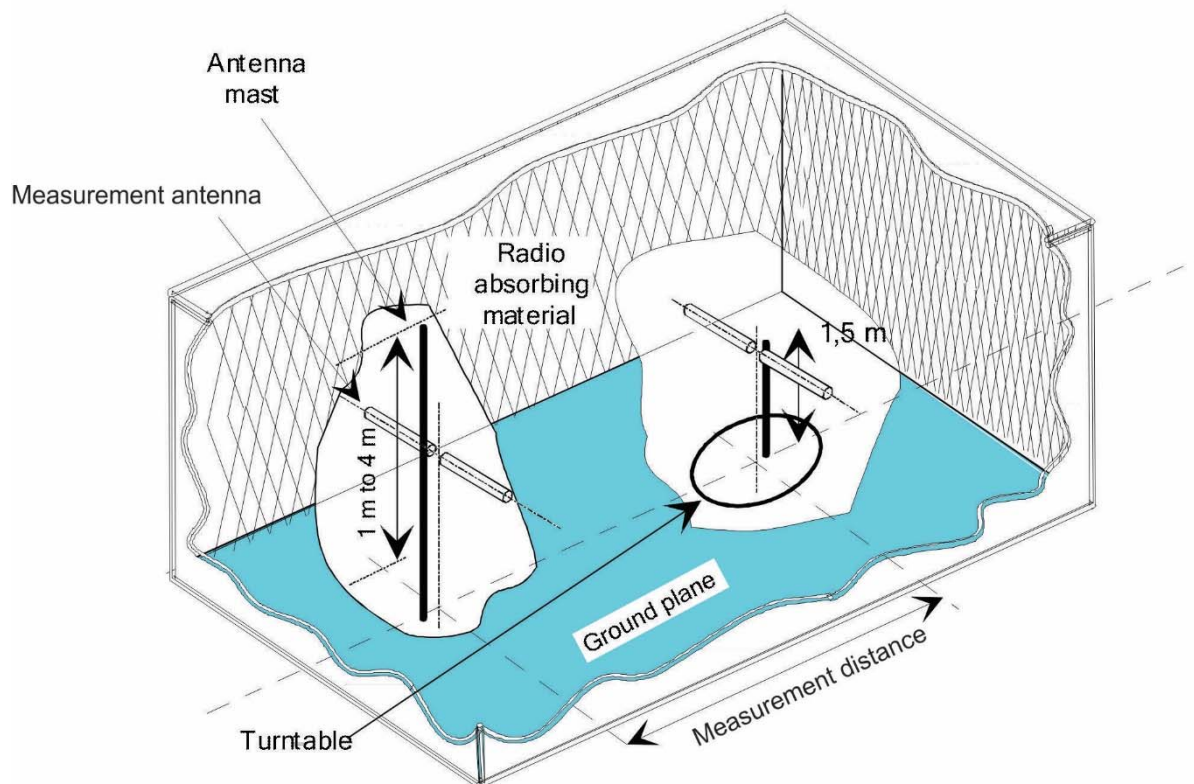

Figure B.2.2-1: A typical Semi Anechoic Room

In this facility the ground plane creates a wanted reflection path, such that the signal received by the receiving antenna is the sum of the signals received from the direct and reflected transmission paths. The phasing of these two signals creates a unique received level for each height of the transmitting antenna (or EUT) and the receiving antenna above the ground plane.

The antenna mast provides a variable height facility (from 1 m to 4 m) so that the position of the measurement antenna can be optimized for maximum coupled signal between antennas or between a EUT and the measurement antenna.

A turntable is capable of rotation through 360° in the horizontal plane and it is used to support the test sample (EUT) at a specified height, 1,5 m above the ground plane.

The measurement distance and minimum chamber dimensions can be found in clause B.2.4. The distance used in actual measurements shall be recorded with the test results.

Further information on Semi Anechoic Rooms can be found in ETSI TR 102 273-3 [i.14].

B.2.3 Fully Anechoic Room (FAR)

A Fully Anechoic Room is an enclosure, usually shielded, whose internal walls, floor and ceiling are covered with radio absorbing material. The chamber usually contains an antenna support at one end and a turntable at the other end. A typical Fully Anechoic Room is shown in Figure B.2.3-1.

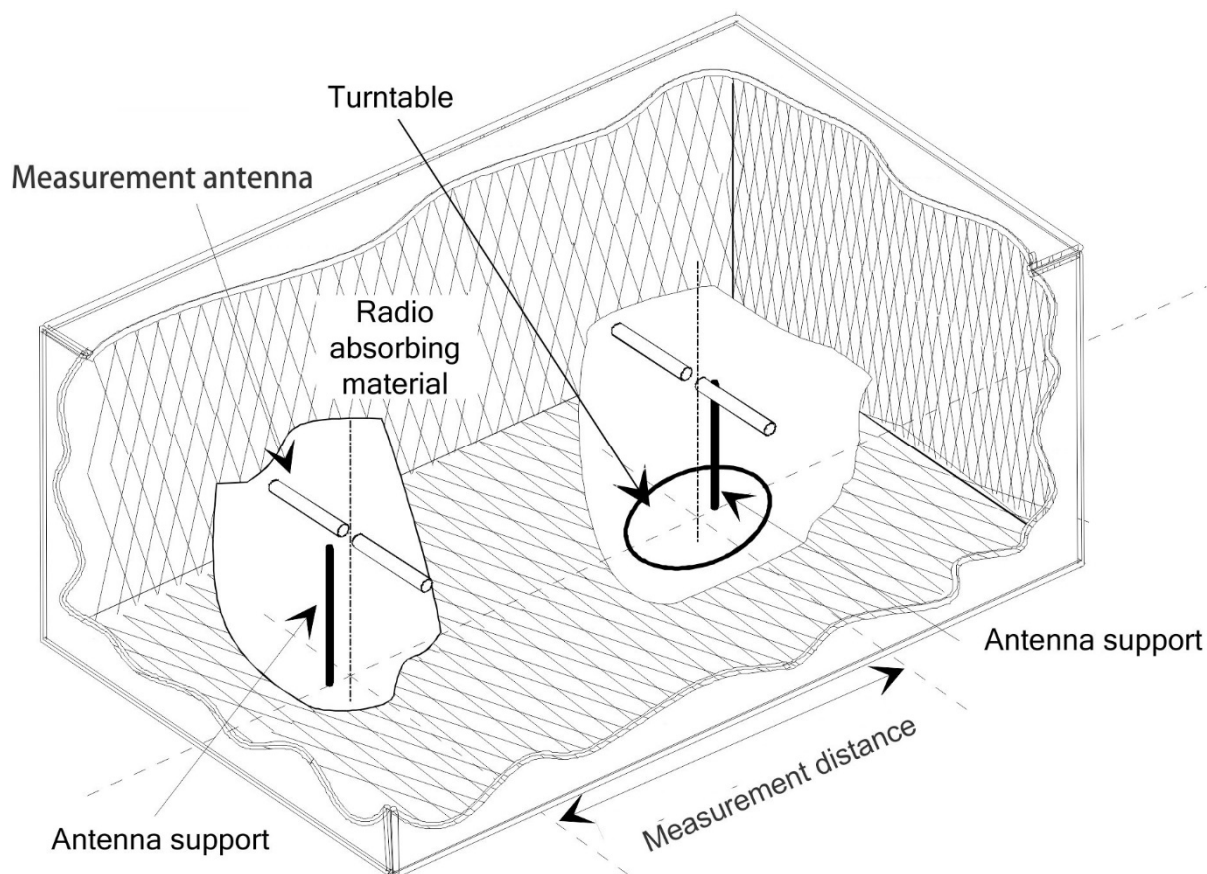

Figure B.2.3-1: A typical Fully Anechoic Room

The chamber shielding and radio absorbing material work together to provide a controlled environment for testing purposes. This type of test chamber attempts to simulate free space conditions.

The shielding provides a test space, with reduced levels of interference from ambient signals and other outside effects, whilst the radio absorbing material minimizes unwanted reflections from the walls and ceiling which can influence the measurements. The shielding should be sufficient to eliminate interference from the external environment that would mask any signals that shall be measured.

A turntable is capable of rotation through 360° in the horizontal plane and it is used to support the EUT at a height of 1,5 m above the ground plane.

The measurement distance and minimum chamber dimensions can be found in clause B.2.4. The distance used in actual measurements shall be recorded with the test results.

Further information on Fully Anechoic Rooms can be found in ETSI TR 102 273-2 [i.15].

B.2.4 Measurement Distance

The measurement distance should be chosen in order to measure the EUT at far-field conditions. The minimum measurement distance between the equipment and the measurement antenna should be λ or $r_m \gg \frac{D^2}{\lambda}$, whichever is the greater.

λ = wavelength in m

r_m = minimum measurement distance between EUT and measurement antenna in m

D = largest dimension of physical aperture of the largest antenna in the measurement setup, in m

$\frac{D^2}{\lambda}$ = distance between outer boundary of radiated near field (Fresnel region) and inner boundary of the radiated far-field (Fraunhofer region) in m, also known as Rayleigh distance.

3 m or 10 m are recommended measurement distances, where these conditions cannot be fulfilled and where the measurement distance would result in measurements in the near field (e.g. while measuring spurious emissions), this should be noted in the test report and the additional measurement uncertainty should be incorporated into the results. The measurement distance may also depend on the EUT size (e.g. 3 m distance when an EUT is mounted on/in a car is not allowed because EUT is exceeding the quiet zone of the test site).

B.3 Antenna

B.3.1 General considerations

Antennae are needed for the radiated measurements on the three test sites described in clause B.2. Depending on its use, the antenna will be designated as "measurement antenna" or "substitution antenna".

B.3.2 Measurement antenna

In emission tests the measurement antenna is used to detect the field from the EUT in one stage of the measurement, and from the substitution antenna in the other stage. When the test site is used for the measurement of receiver characteristics, the antenna is used as the transmitting device.

The measurement antenna should be mounted on a support capable of allowing the antenna to be used in either horizontal or vertical polarization. Additionally, on an OATS or SAR, the height of the centre of the antenna above the ground should be variable over the specified range 1 m to 4 m.

In the frequency band 30 MHz to 1 000 MHz, Logarithmic Periodic Dipole Antennas (LPDAs) are recommended. Above 1 GHz, horn antennas or logarithmic periodic dipole antennas are recommended.

For spurious emission testing, however, a combination of biconical antennas (commonly termed "bicones") and log periodic dipole array antennas (commonly termed "log periodics") could be used to cover the entire 30 MHz to 1 000 MHz band.

B.3.3 Substitution antenna

The substitution antenna shall be used to replace the equipment under test in substitution measurements and shall be suitable for the frequency range and the return loss of the antenna shall be taken into account when calculating the measurement uncertainty.

The phase centre of the substitution antenna shall coincide with the reference point of the test sample it has replaced. Therefore antennas with a phase centre that changes as a function of frequency (such as a LPDA) are not suitable for use as a substitution antenna.

The reference point of the substitution antenna shall coincide with the volume centre of the EUT when its antenna is internal, or the point where an external antenna is connected to the EUT.

The distance between the lower extremity of the antenna and the ground shall be at least 30 cm.

The substitution antenna shall be calibrated for the test site (OATS, SAR, FAR) in which it will be used. Below 1 GHz, the calibration is relative to a half wave dipole, while above 1 GHz, an isotropic radiator is the reference.

NOTE: Calibration figures intended for use above a reflective surface cannot be used in an anechoic chamber or vice versa.

B.4 Guidance on the use of radiation test sites

B.4.1 General considerations

This clause details procedures, test equipment arrangements and verification that should be carried out before any of the radiated test are undertaken. These schemes are common to all types of test sites described in clause B.2.

Where necessary, a mounting bracket of minimal size should be available for mounting the EUT on the turntable. This

bracket should be made from low conductivity, low relative permittivity (i.e. $\frac{\epsilon}{\epsilon_0} < 1,5$) material(s) such as expanded polystyrene, balsawood, etc.

B.4.2 Power supplies for the battery powered EUT

All tests should be performed using power supplies wherever possible, including tests on EUT designed for battery-only use. For battery powered equipment, power leads should be connected to the EUT's supply terminals (and monitored with a digital voltmeter) but the battery should remain present, electrically isolated from the rest of the equipment, possibly by putting tape over its contacts.

The presence of these power cables can, however, affect the measured performance of the EUT. For this reason, they should be made to be "transparent" as far as the testing is concerned. This can be achieved by routing them away from the EUT and down to the either the screen, ground plane by the shortest possible paths. Power cables shall be equipped with ferrite immediately at EUT. Ferrite bead shall present an impedance of at least 100 Ω at 100 MHz.

B.4.3 Site preparation

The cables to the measuring and substitution antenna should be routed horizontally away from the testing area for a minimum of 2 m (unless, in the case both types of anechoic chamber, a back wall is reached) and then allowed to drop vertically and out through either the ground plane or screen (as appropriate) to the test equipment. Precautions should be taken to minimize pick up on these leads (e.g. dressing with ferrite beads, or other loading). The cables, their routing and dressing should be identical to the verification set-up.

NOTE: For ground reflection test sites (i.e. anechoic chambers with ground planes and Open Area Test Sites) which incorporate a cable drum with the antenna mast, the 2 m requirement may be impossible to comply with.

Calibration data for all items of test equipment should be available and valid. For test, substitution and measuring antennas, the data should include gain relative to an isotropic radiator (or antenna factor) for the frequency of test. Also, the VSWR of the substitution and measuring antennas should be known.

The calibration data on all cables and attenuators should include insertion loss and VSWR throughout the entire frequency range of the tests. All VSWR and insertion loss figures should be recorded in the log book results sheet for the specific test.

Where correction factors/tables are required, these should be immediately available.

B.5 Coupling of signals

B.5.1 General

The presence of leads in the radiated field may cause a disturbance of that field and lead to additional measurement uncertainty. These disturbances can be minimized by using suitable coupling methods, offering signal isolation and minimum field disturbance (e.g. optical coupling).

B.5.2 Data signals

Isolation can be provided by the use of optical, ultrasonic or infra-red means. Field disturbance can be minimized by using a suitable fibre optic connection. Ultrasonic or infra-red radiated connections require suitable measures for the minimization of ambient noise.

B.6 Measurement procedures for radiated measurement

B.6.1 General considerations

This annex gives the general procedures for radiated measurements using the test sites and arrangements described in clause B.2.

B.6.2 Radiated measurements in an OATS or SAR

Radiated measurements shall be performed with the aid of a measurement antenna and a substitution antenna, in test sites described in clause B.2. The measurement set-up shall be calibrated according to the procedure defined in this clause B.6. The EUT and the measurement antenna shall be oriented such as to obtain the maximum emitted power level. This position shall be recorded in the measurement report:

- 1) The measurement antenna (device 2 in Figure B.6.2-1) shall be oriented initially for vertical polarization unless otherwise stated and the EUT (device 1 in Figure B.6.2-1) shall be placed on the support in its standard position and switched on.
- 2) The measurement equipment (device 3 in Figure B.6.2-1) shall be connected to the measurement antenna and set-up according to the specifications of the test.

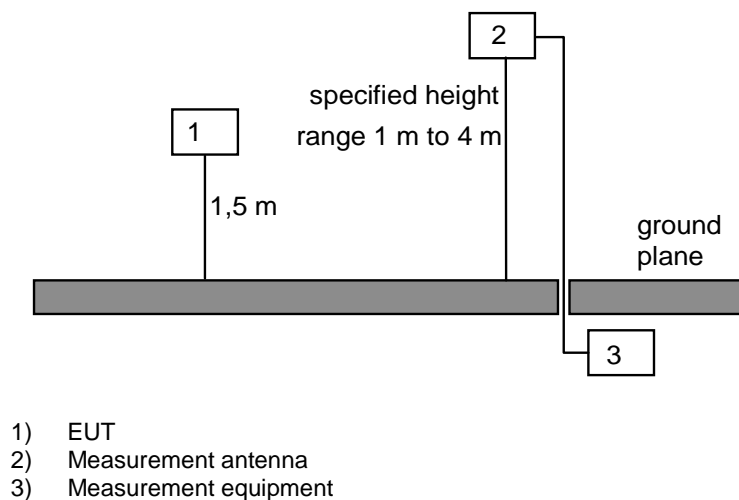

Figure B.6.2-1: Measurement arrangement No.1

- 3) The EUT shall be rotated through 360° in a horizontal plane until a maximum signal is received.
- 4) The measurement antenna shall be raised or lowered again through the specified height range until a maximum is obtained.
- 5) The maximum signal level shall be recorded.

NOTE: This maximum may be a lower value than the value obtainable at heights outside the specified limits.

- 6) The measurement shall be repeated with the measurement antenna oriented for horizontal polarization.

B.6.3 Radiated measurements in a FAR

For radiated measurements using a FAR, the procedure is identical to the one described in clause B.6.2, except that step 4) is omitted.

B.6.4 Substitution measurement

To determine the absolute measurement value a substitution measurement is performed. The following steps shall be performed:

- 1) The EUT, depicted as Device 1 in Figure B.6.2-1, shall be replaced by a substitution antenna oriented for vertical polarization. A calibrated signal generator shall be connected to the substitution antenna, and adjusted to the measurement frequency.
- 2) If an OATS or a SAR is used, the measurement antenna shall perform a height scan from 1 m to 4 m, to ensure that the maximum signal is received.
- 3) Subsequently, the power of the signal generator shall be adjusted until the level obtained at the measurement equipment is the same as that recorded in the radiated measurement performed in clause B.6.2 or B.6.3 for the same polarization as the substitution antenna.
- 4) The absolute radiated power is equal to the power supplied by the signal generator, increased by the substitution antenna gain minus the cable losses (the values of antenna gain and cable losses are in dB).
- 5) This measurement shall be repeated with the substitution antenna oriented for horizontal polarization.

NOTE: For test sites with a fixed setup of the measurement antenna(e) and a reproducible positioning of the EUT, correction values from a verified site calibration can be used.

B.6.5 Radiated measurement methods for receivers

Radiated measurements on receiving equipment are made with the output of the signal generator connected to the measurement antenna which is used as the test antenna as specified in clause B.3.2.

The power level at the receiver input is obtained by replacing the EUT with a substitution antenna (as specified in clause B.3.3) and suitable measuring equipment.

NOTE 1: The substitution antenna gain relative to a half wave dipole should be known.

There are two measurement methods:

- a) Connect the substitution antenna to a calibrated measuring receiver and read the measurement result directly, corrected for the substitution antenna gain.
- b) Measure the path loss from the measurement antenna to the substitution antenna and subtract this, corrected for the substitution antenna gain, from the signal generator level to obtain the measurement result.

NOTE 2: For method a), if the level received is too low for accurate reading, the level of the signal generator may be increased by a suitable amount and the equivalent offset applied to the measurement result.

NOTE 3: Method b), one calibration measurement can be used for multiple tests.

B.7 Guidance for testing radiated technical requirements

B.7.0 General

This clause provides guidance on how the various technical requirements can be verified using radiated measurements.

B.7.1 Radio test suites and corresponding test sites

Table B.7.1-1 provides guidance on the test site to be used for each of the radio tests when performing radiated measurements on equipment with integral antenna.

Table B.7.1-1: Radio conformance tests and corresponding test sites

Radio conformance test - Clause number	Small size EUT corresponding test site - Clause number(s)	Medium size EUT corresponding test site - Clause number(s)	Large size EUT corresponding test site - Clause number(s)
5.3	B.2.3 (FAR)	B.2.2 (SAR)	B.2.1 (OATS)
5.4	B.2.3 (FAR)	B.2.2 (SAR)	B.2.1 (OATS)
5.5	B.2.3 (FAR)	B.2.2 (SAR)	B.2.1 (OATS)
5.6	B.2.3 (FAR)	B.2.2 (SAR)	B.2.1 (OATS)
Additional condition	If B.2.3 test site (FAR) is not available, B.2.2 (SAR) shall be used instead, but measurements may be influenced by the ground plane reflections. A specific calibration of path loss is required.	If B.2.2 test site (SAR) is not available, B.2.1 (OATS) shall be used instead, but measurements may be influenced by the ground plane reflections. A specific calibration of path loss is required.	

Small size EUT is an EUT with the largest dimension excluding leads < 1 m.

Medium size EUT is an EUT with the largest dimension excluding leads between ≥ 1 m and 2 m.

Large size EUT is an EUT with the largest dimension excluding leads is ≥ 2 m

Annex C (informative): Selection of receiver parameters

C.0 Introduction

Receiver parameters under article 3.2 of Directive 2014/53/EU [i.1] listed in ETSI EG 203 336 V1.2.1 [i.12] are analysed and the parameters which are applicable to the present document are specified in respective clauses.

C.1 Receiver sensitivity

Receiver sensitivity is the ability to receive a wanted signal at low input signal levels while providing a pre-determined level of performance. Receiver sensitivity is specified in clause 4.4.1.

C.2 Receiver co-channel rejection

Receiver co-channel rejection is a measure of the capability of a receiver to receive a wanted signal, without exceeding a given degradation, due to the presence of an unwanted signal, both signals being at the nominal frequency of the receiver.

In frequency bands covered by the present document, any modulation, channel width, centre frequency and data rate may be used. A combination of many signals of widely different characteristics manifests itself primarily as an increase in the noise floor.

Thus, a specific test for co-channel rejection is not included because the co-channel rejection performance of the receiver combined with the receiver noise figure directly affects the sensitivity performance, which is tested. The required limits for sensitivity ensure that products have the required co-channel rejection.

Moreover, the wideband data transmission SRD device employs listen-before-talk technique to ensure the device operates in a channel with limited co-channel energy.

C.3 Receiver adjacent signal selectivity

Adjacent channel selectivity is a measure of the receiver capability to receive a wanted modulated signal without exceeding the general performance criteria stated in clause 4.2 of the present document due to the presence of an unwanted input signal in the adjacent channels. Adjacent channel selectivity is specified in clause 4.4.2.

C.4 Receiver spurious response rejection

The spurious response rejection is a measure of the capability of the receiver to receive a wanted signal without exceeding a given degradation due to the presence of an unwanted signal at any frequency at which a response is obtained. The frequencies of the adjacent signals (channels) are excluded.

Receiver spurious response rejection is specified in clause 4.4.3.

C.5 Receiver blocking

Blocking is a measure of the receiver capability to receive a wanted modulated signal without exceeding a given degradation due to the presence of an unwanted input signal at any frequencies other than those of the spurious responses or the adjacent channels or bands. Receiver Blocking is specified in clause 4.4.4.

C.6 Receiver radio-frequency intermodulation

Intermodulation rejection is a measure of the ability of a receiver to operate in the presence of two or more unwanted signals the frequencies of which have a specific frequency relationship to the wanted signal.

Limits for reciprocal mixing effects are difficult to specify for wideband data transmission with frequency bands with a wide range of modulations, channel widths and data rates.

Intermodulation effects will manifest themselves as blocking effects and the present document relies on limits and test suites for blocking and adjacent channel selectivity to ensure receiver resilience in the shared spectrum environment.

C.7 Receiver dynamic range

Receiver dynamic range is defined as the range of the wanted input signal level over which a receiver functions at a specified performance level. Dynamic range is provided by a combination of the sensitivity requirement and the maximum input signal level requirement. Maximum input signal level is specified in clause 4.4.6.

C.8 Desensitization

Desensitization is a measure of the ability of the receiver to operate in the presence of a strong interfering signal. Receiver susceptibility to desensitization is provided by the blocking requirement and adjacent channel selectivity requirement.

C.9 Receiver unwanted emissions in the spurious domain

As a default, the limit for unwanted emissions in the spurious domain referenced at the antenna port should respect those in ERC/REC 74-01 [i.9]. Receiver unwanted emissions are specified in clause 4.4.5.

Annex D (normative): T_{On} time measurements

D.1 Measurement procedure

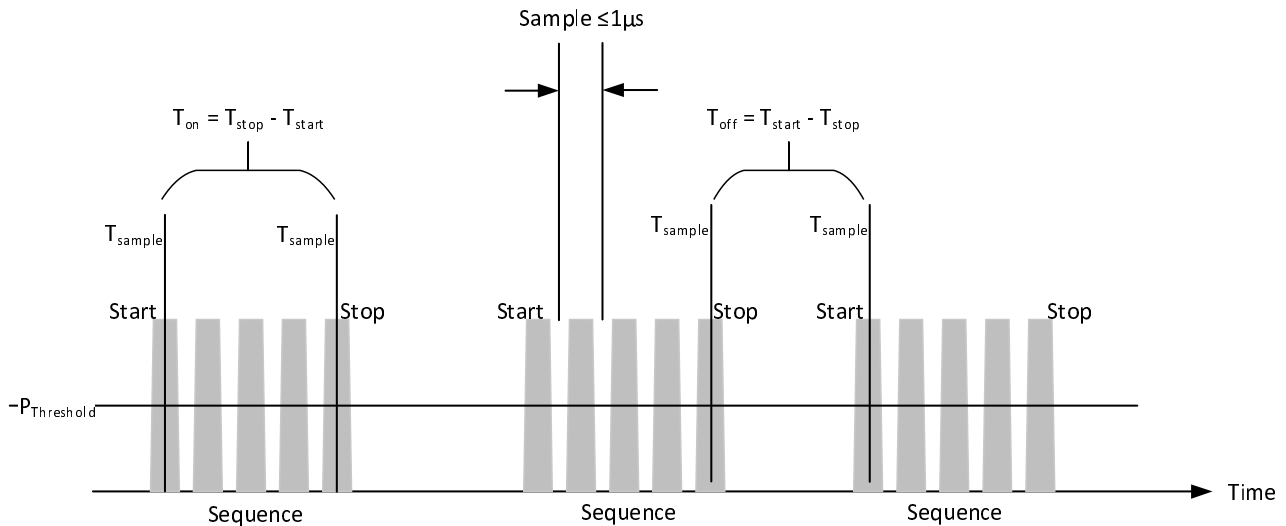

Figure D.1-1: Power samples reference timing

The start time and stop time of each sequence of samples above $P_{\text{Threshold}}$ shall be determined. The timing reference for samples shall be as shown in Figure D.1-1. The T_{On} time shall be calculated from the difference between the time of the first and last samples of the sequence. The start time, stop time and T_{On} time for each sequence shall be saved.

Between the saved stop and start times of two adjacent sequences, the T_{Off} time shall be calculated. These T_{Off} values shall be saved.

D.2 T_{Disregard} procedure

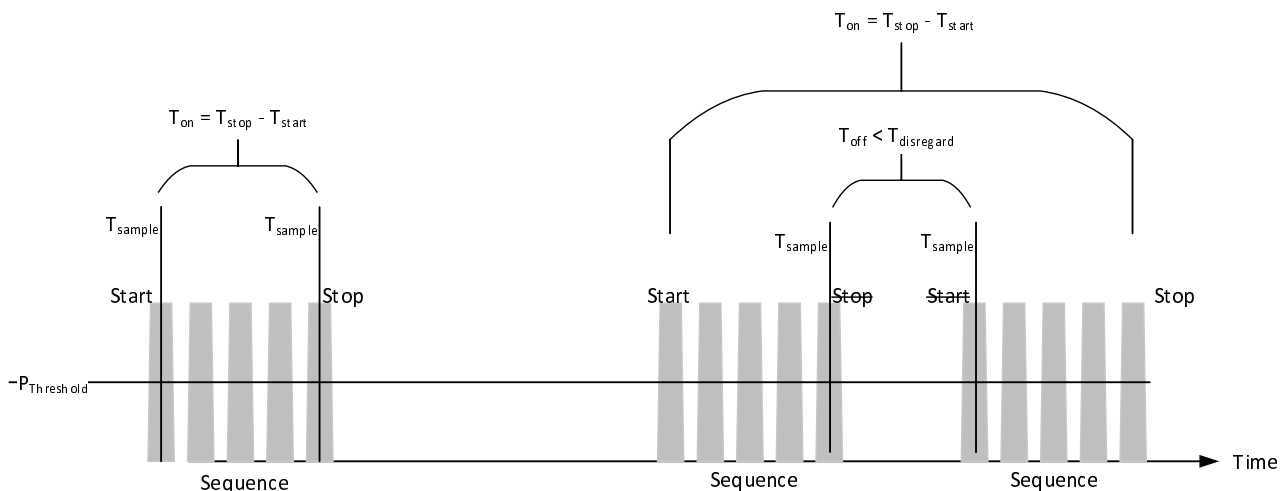

Figure D.2-1: T_{Disregard}

Within the calculated T_{Off} times, for each interval less than $T_{\text{Disregard}}$ the preceding sequence and the following sequence shall be merged with the T_{Off} interval and shall be replaced with the resulting combined start, stop and T_{On} times as shown in Figure D.2-1.

Annex E (normative): Test fixture

E.1 General considerations

With equipment intended for use with an integral antenna, and not equipped with a 50 Ω RF output connector, a suitable test fixture as shown in Figure E.1-1 shall be used.

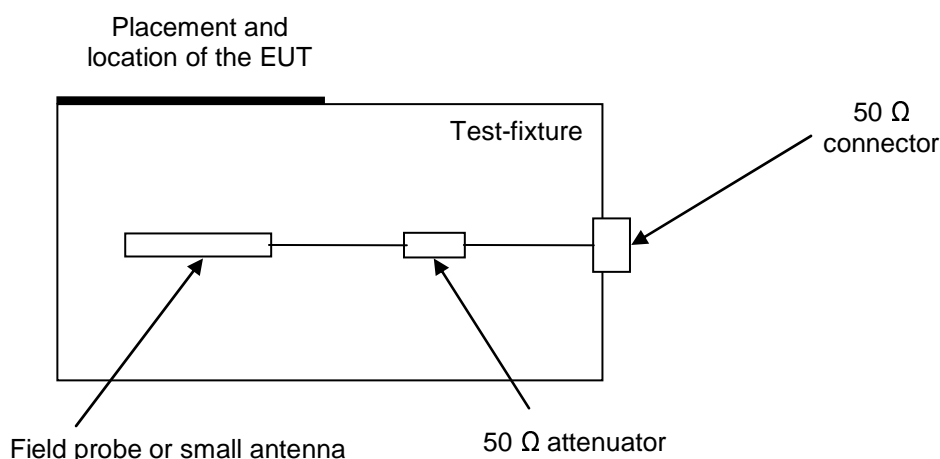

Figure E.1-1: Test fixture

Where a test fixture as defined in the present clause is used for measurements on integral antenna equipment, tests on radiated signals shall be carried out using the test fixture.

This fixture is a radio frequency device for coupling the integral antenna to a 50 Ω RF terminal at all frequencies for which measurements need to be performed.

In addition, the test fixture may provide:

- a) a connection to an external power supply;
- b) a method to provide the input to or output from the equipment.

NOTE: This may include coupling to or from the antenna. The test fixture could also provide suitable coupling means e.g. for data or video outputs.

The performance characteristics of the test fixture shall conform to the following basic parameters:

- a) the coupling loss shall not be greater than 30 dB;
- b) a coupling loss variation over the frequency range used in the measurement which does not exceed 2 dB under all test conditions;
- c) circuitry associated with the RF coupling shall contain no active or non-linear devices;
- d) the VSWR at the 50 Ω socket shall not be more than 1,5 over the frequency range of the measurements;
- e) the coupling loss shall be independent of the position of the test fixture and be unaffected by the proximity of surrounding objects or people. The coupling loss shall be reproducible when the equipment under test is removed and replaced. Normally, the test fixture is in a fixed position and provides a location for the EUT.

The attenuation of the test fixture coupling should be such that the received signal at the measuring instrument is at least 10 dB above the measuring instrument noise floor. If the attenuation is too great it can be compensated by linear amplification outside the test-fixture.

The characteristics and validation of the test fixture shall be documented in the test report.

E.2 Validation of the test-fixture in the temperature chamber

The following is an example test fixture validation procedure to be followed if test fixture measurements are performed under extreme temperature conditions.

A description of the validation procedure used shall be included in the test report.

The test fixture is brought into a temperature chamber.

Step 1:

As shown in Figure E.2-1, a test antenna connected to a signal generator shall be positioned from the test-fixture at a far field distance of not less than one λ at the frequency. The test fixture consists of the mechanical support for the EUT, an antenna or field probe and a $50\ \Omega$ attenuator for proper termination of the field probe. The test fixture shall be connected to a spectrum analyser via the $50\ \Omega$ connector.

The signal generator shall be set to operate on the nominal frequency of the EUT. The unmodulated output power of the signal generator shall be set to a value such that a sufficiently high level can be observed with the spectrum analyser. This value shall be recorded in the test report. The signal generator shall then be set to the upper and the lower band limit of the EUT's Permitted Frequency Band. The measured values shall not deviate more than 1 dB from the value at the nominal frequency. The distance between test antenna and test fixture may be reduced to $\lambda/2$ for frequencies below 100 MHz.

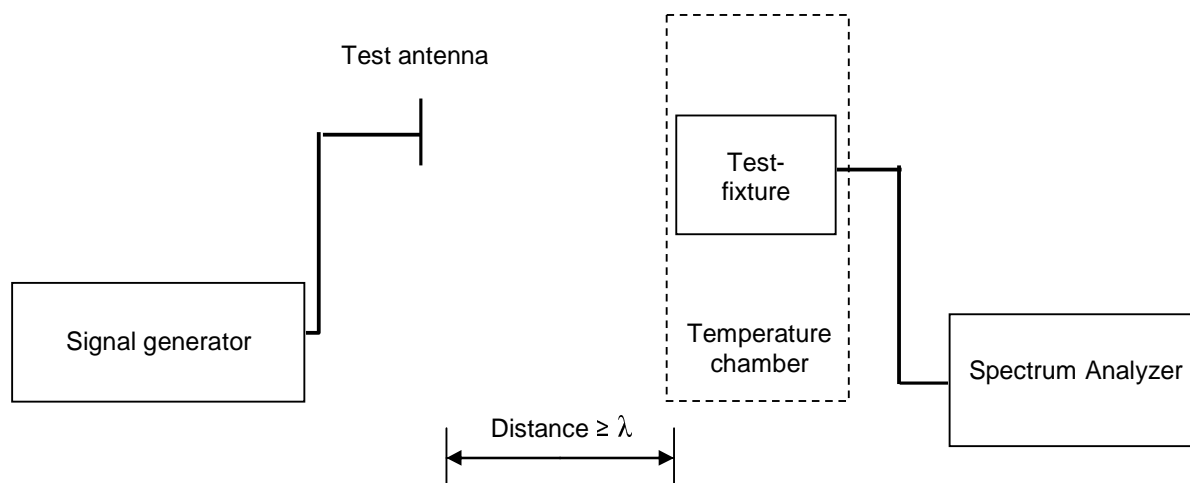

Figure E.2-1: Validation of test set-up without EUT

Step 2:

During validation and testing the EUT shall be fitted to the test fixture in a switched-off mode as shown in Figure E.2-2. Step 1 shall be repeated, this time with the EUT in place. The measured values shall be compared with those from step 1 and may not vary by more than 2 dB. This shows that the EUT does not cause any significant shadowing of the radiated power.

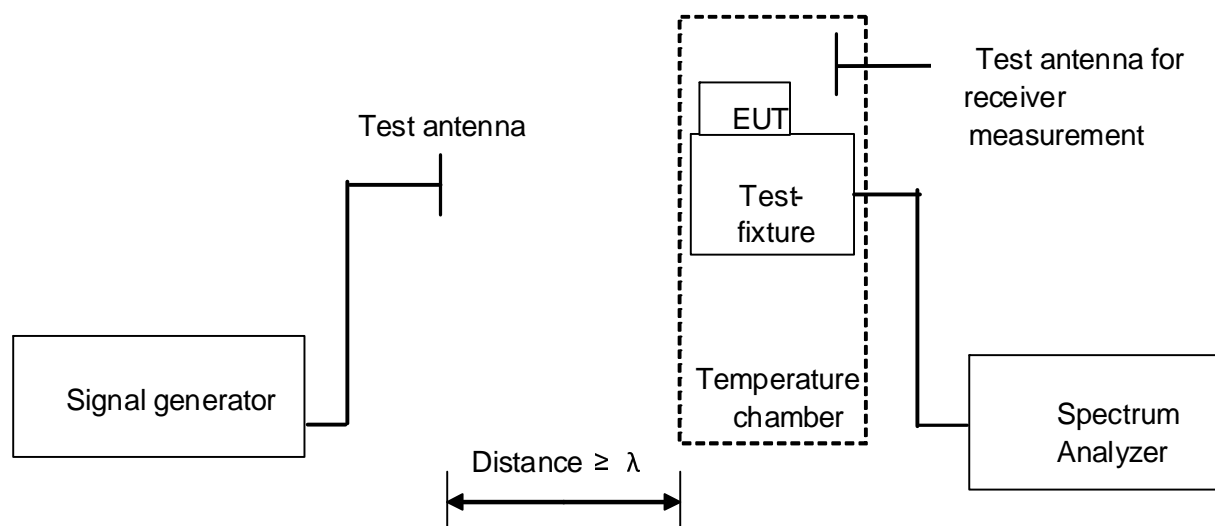

Figure E.2-2: Validation of test set-up with EUT in place

Step 3:

In the case of a battery operated EUT that is supplied by a temporary voltage feed, a decoupling filter shall be installed directly at the EUT in order to avoid parasitic electromagnetic radiation. See Figure E.2-3.

In this step the signal generator and the transmit antenna are removed.

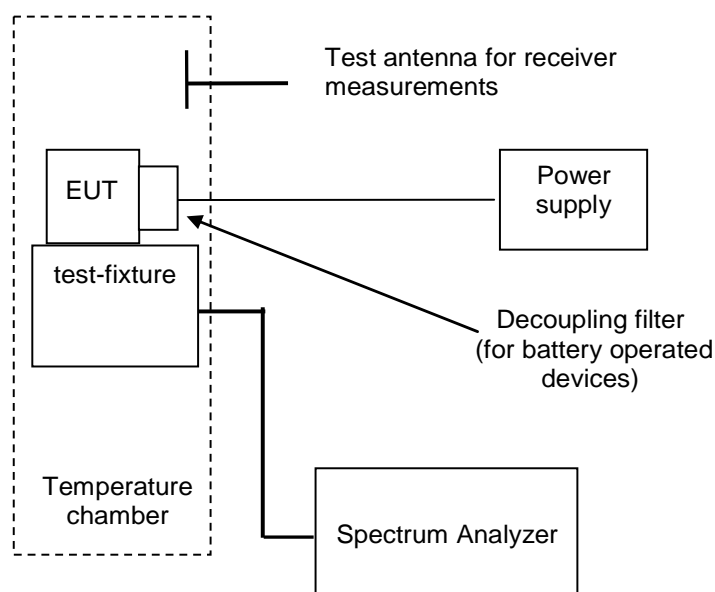

Figure E.2-3: Test of EUT

E.3 Mode of use

The test fixture may be used to facilitate some of the transmitter and receiver measurements in the case of equipment having an integral antenna.

Annex F (informative): Properties of EUT

This annex lists the EUT properties necessary for the execution of the conformance test suites used to determine the conformance of the EUT. This application form should form an integral part of the test report.

Table F-1

Property	Value	Units
Permitted Frequency Band		MHz
Operating channel(s) and nominal operating frequency of each channel		MHz
Local oscillator frequency (f_{LO})		MHz
Intermediate frequency (f_{IF})		MHz
Intermediate frequency (f_{IF1}) and (f_{IF2}) in case of second IF filter		
External antenna gain relative to dipole		
For equipment with non-integral antenna		dBd
Technical description of D-M2, D-M2a, D-M3 (Information necessary to be able to synthesize test signals representative of normal operation)		
Unmodulated carrier, if the equipment is able to generate test signal D-M1 or not		
Upper and lower temperatures of the environmental profile given by the intended use		°C
Upper and lower voltage range from environmental profile given by the intended use		V
Nominal mains voltage (or range of voltages)		V _{ac}
Nominal battery voltage		V
EUT CCA time		ms
Disregard time ($T_{Disregard}$)		µs

Notwithstanding the provisions of the copyright clause related to the text of the present document, ETSI grants that users of the present document may freely reproduce the application form in this annex so that it can be used for its intended purposes and may further publish the completed application form.

Annex G (informative): Maximum Measurement uncertainty

The measurements described in the present document are based on the following assumptions:

- the measured value related to the corresponding limit is used to decide whether an equipment meets the requirements of the present document;
- the value of the measurement uncertainty for the measurement of each parameter is included in the test report.

Table G-1 shows the recommended values for the maximum measurement uncertainty figures.

Table G-1: Maximum measurement uncertainty

Parameter	Uncertainty
Radio frequency	$\pm 0,5$ ppm
RF power, conducted	$\pm 1,5$ dB
Conducted spurious emission of transmitter, valid up to 6 GHz	± 3 dB
Conducted emission of receivers	± 3 dB
Radiated emission of transmitter, valid up to 6 GHz	± 6 dB
Radiated emission of receiver, valid up to 6 GHz	± 6 dB
RF level uncertainty for a given BER	$\pm 1,5$ dB
Occupied bandwidth	± 5 %
Temperature	$\pm 2,5$ °C
Humidity	± 10 %
Time	± 5 %
Voltage	± 1 %

Annex H (informative): Bibliography

- Ketterling, H-P: "Verification of the performance of fully and semi-anechoic chambers for radiation measurements and susceptibility/immunity testing", 1991, Leatherhead/Surrey.
- ETSI TR 102 313 (V1.1.1): "Electromagnetic compatibility and Radio Spectrum Matters (ERM); Frequency-agile Generic Short Range Devices using listen-Before-Transmit (LBT); Technical Report".
- ITU-R Radio Regulations.
- Recommendation ITU-R SM 328: "Spectra and bandwidth of emissions".

History

Document history			
V1.1.0	September 2022	EN Approval Procedure	AP 20221204: 2022-09-05 to 2022-12-05
V1.2.0	June 2024	SRdAP process	VA 20240802: 2024-06-03 to 2024-08-02
V1.2.1	August 2024	Publication	